

# Hydraulic Clamping Head

MST Corporation

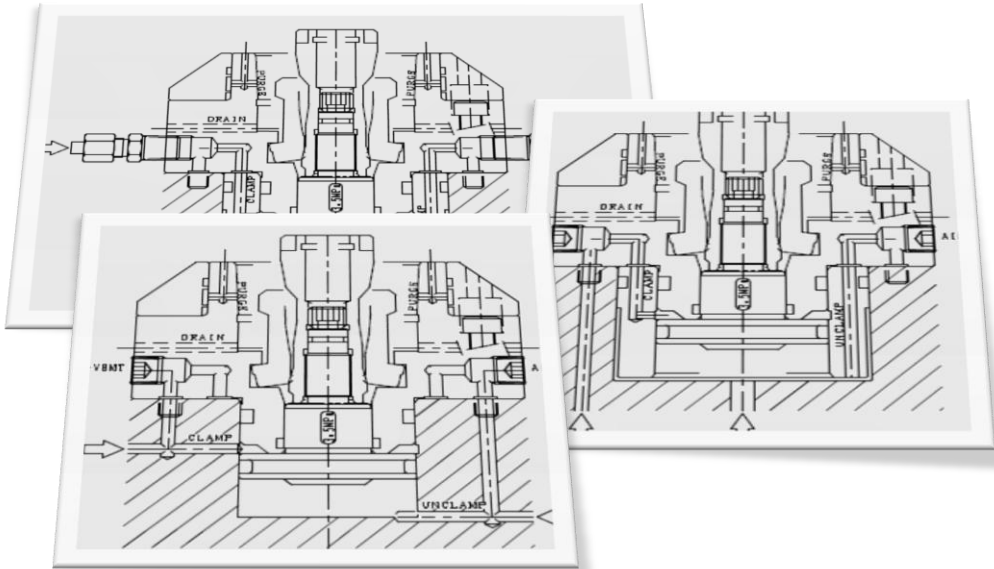
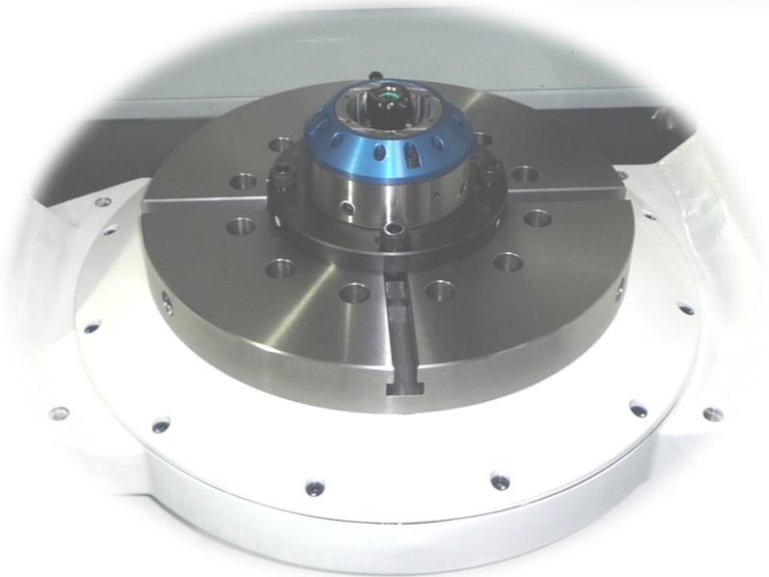
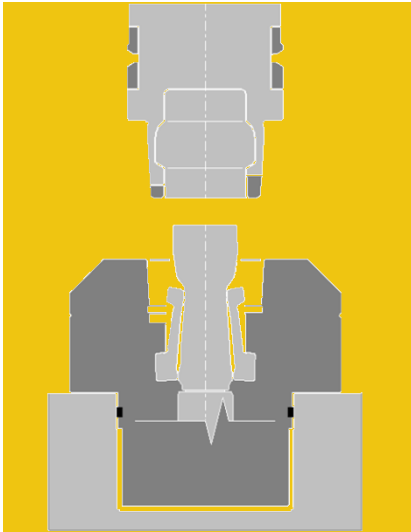

# Feature

## Secure taper lock system “HSK”

The gap-free connection allows for high rigidity and repeating accuracy.

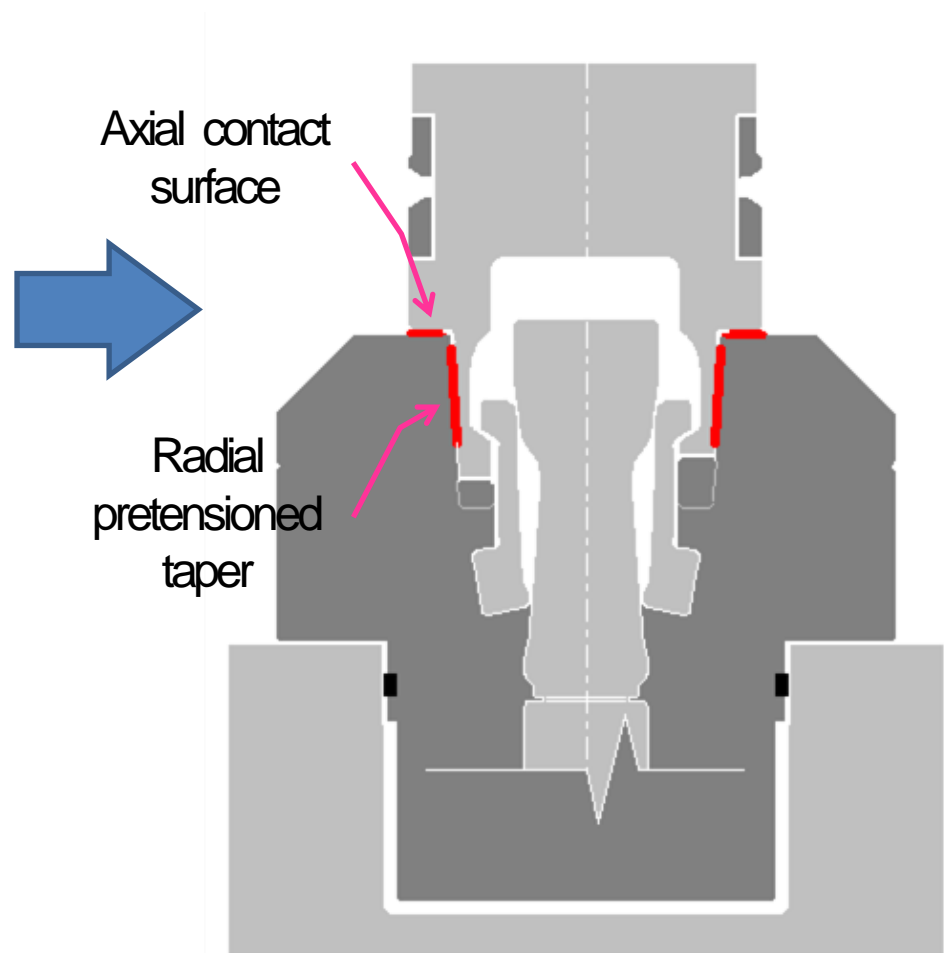
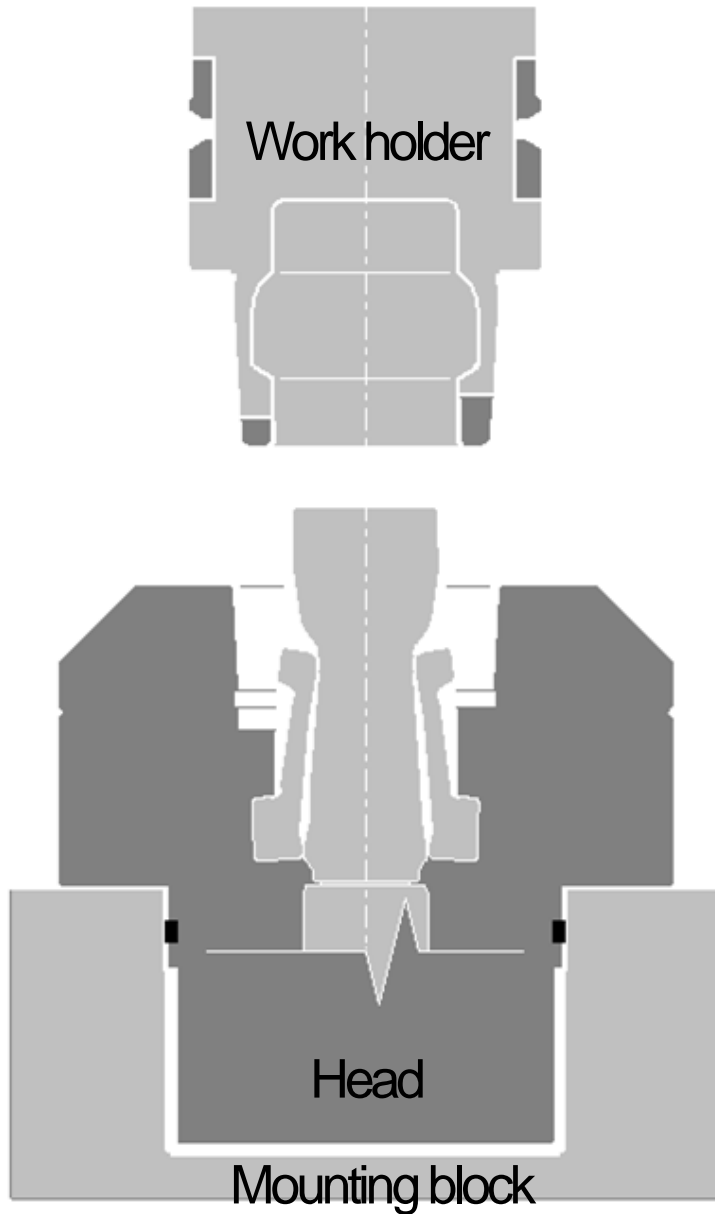

# Feature

---

## Air-purge

Air-purge for a work holder seating surface.

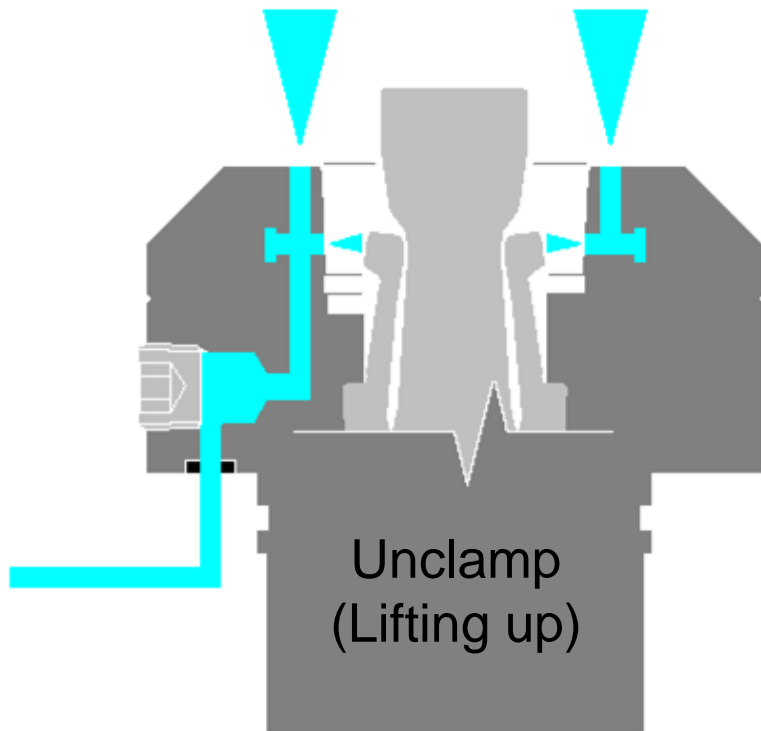

## Seating check

Seating check with using air.

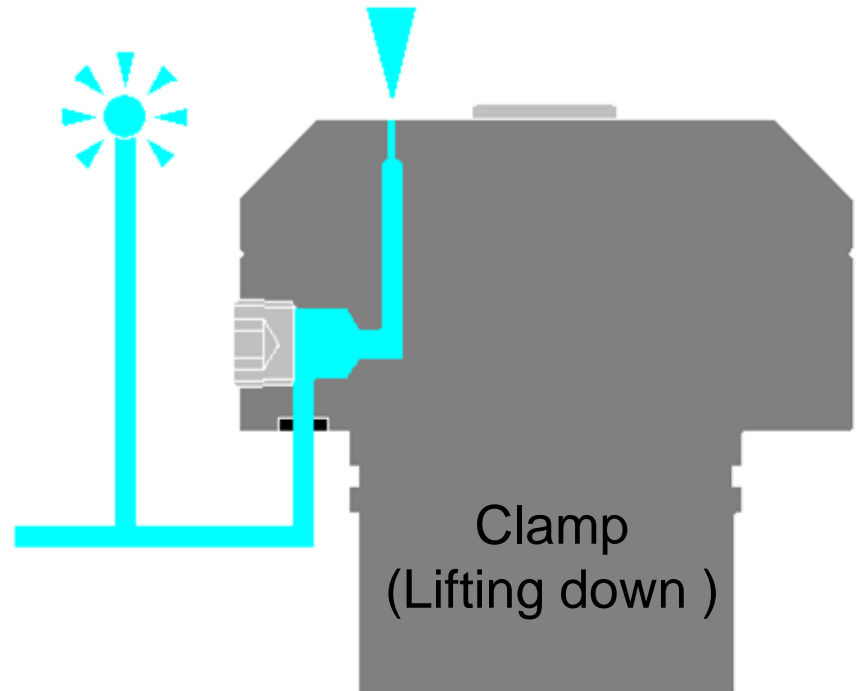

# Feature

---

## Hydraulic circuit

Hydraulic pressure allows for stable clamping force.

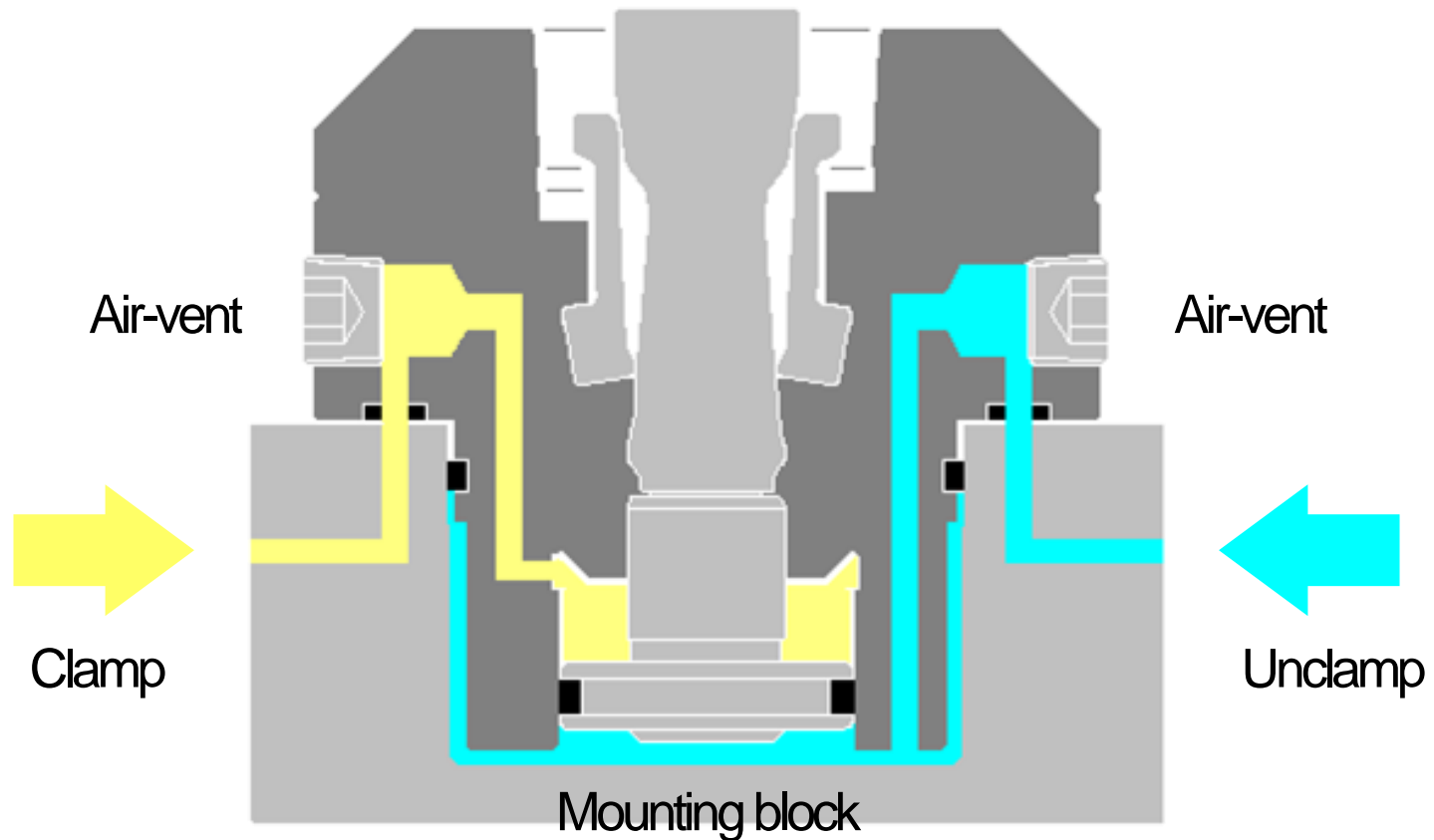

# Action description

## Clamping

\*When the clamping chamber is pressurized, the piston rod is drawn-in and engages the collets with the inner surface of the holder to seat it the datum surface .

\*The air vent hole provided on the seating surface is used for seating confirmation(via air catch sensor).

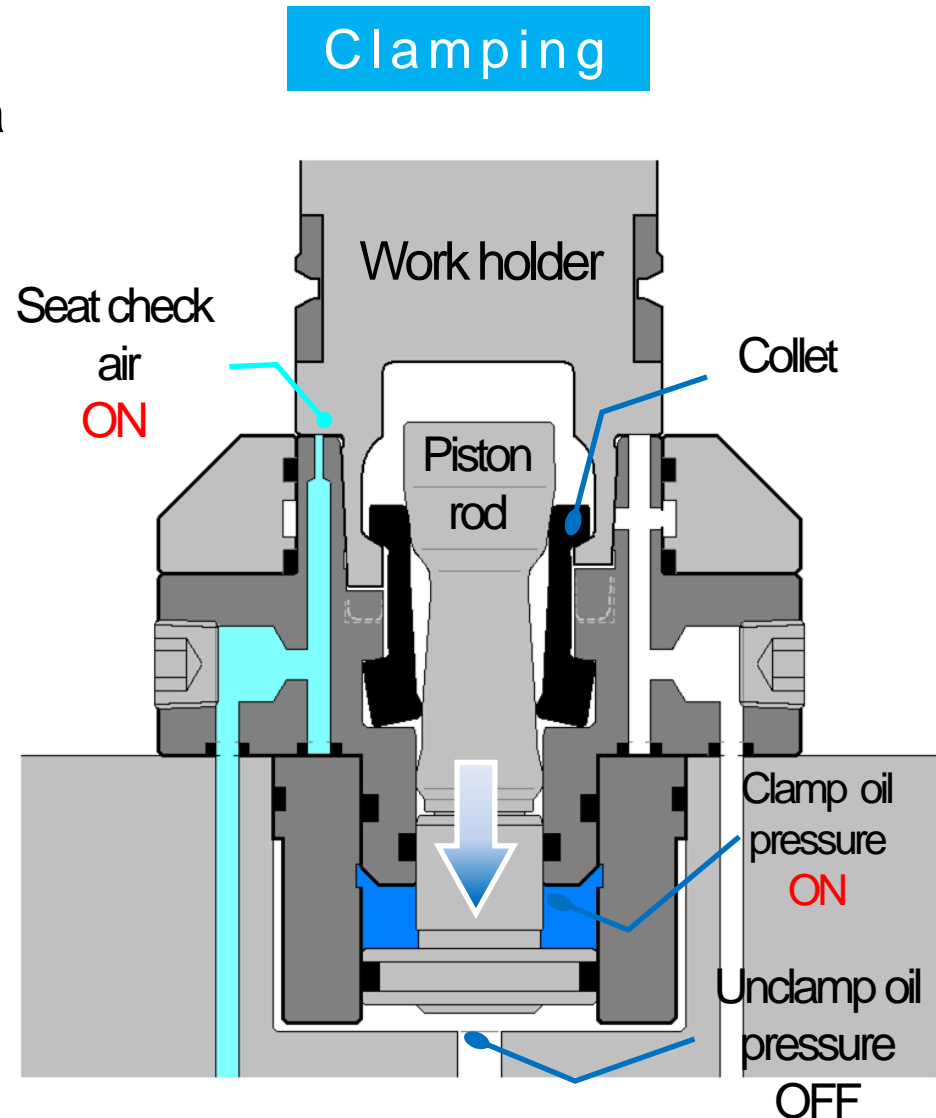

# Action description

## Unclamping

\*When unclamp-chamber is pressurized, the piston rod is raised up and eject the holder while disengaging the collets with it.

\*The holder is lifted on the piston rod and there is a clearance between the datum surfaces. That enables to blow off the cutting chips and fluid effectively.

\*The air-blow flows both tapered and datum surfaces.

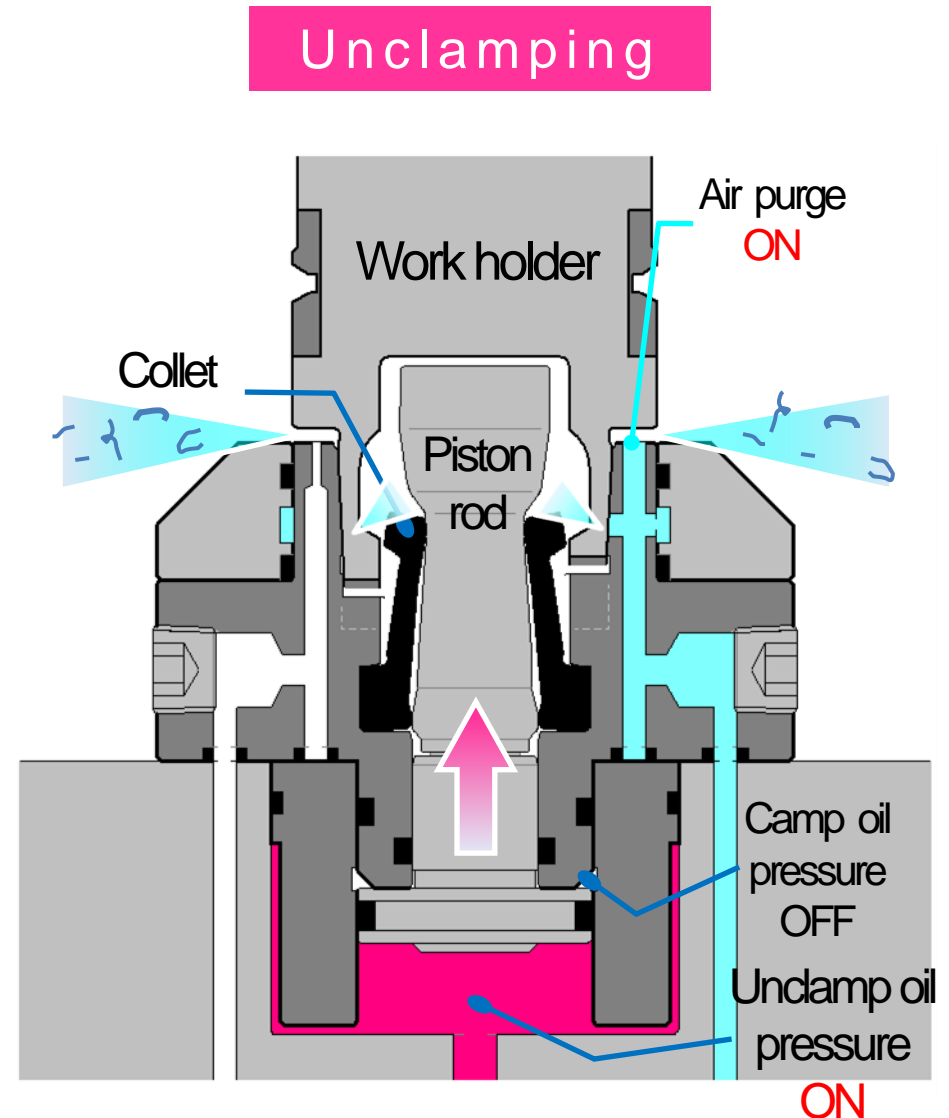

# 5axis machine application

Easy installation for fixtures or works.

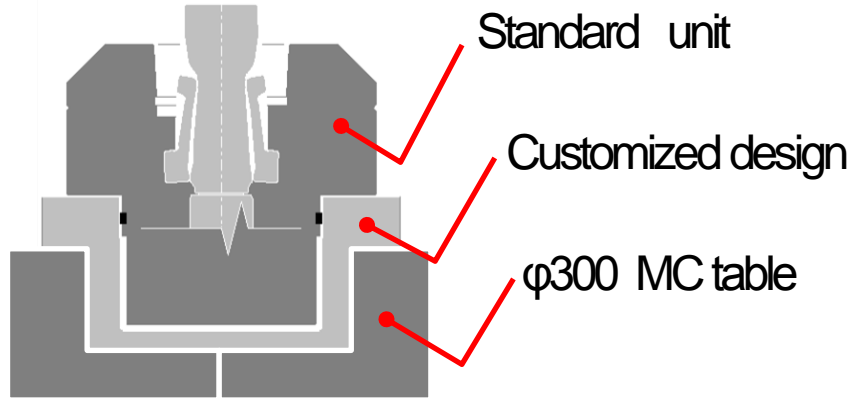

Control box  
Air circuit panel  
Air-hydraulic unit

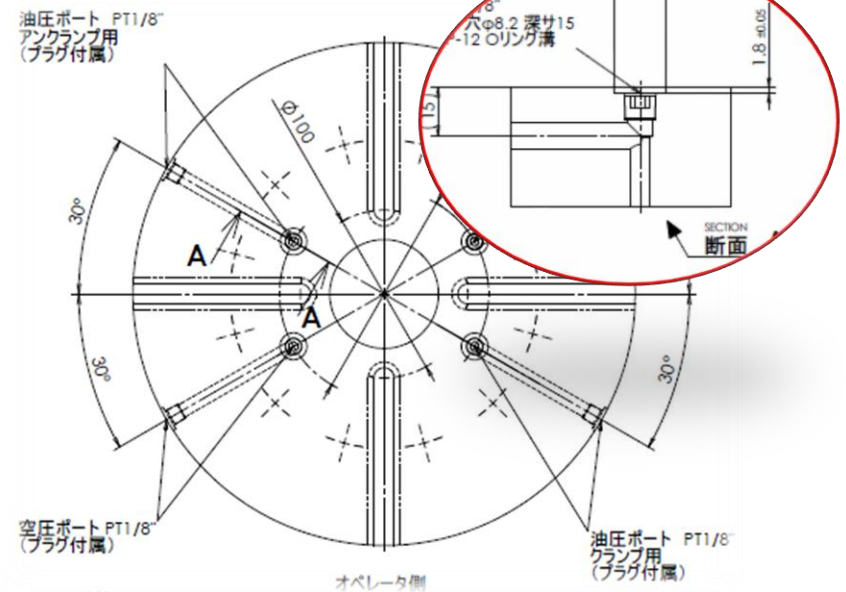
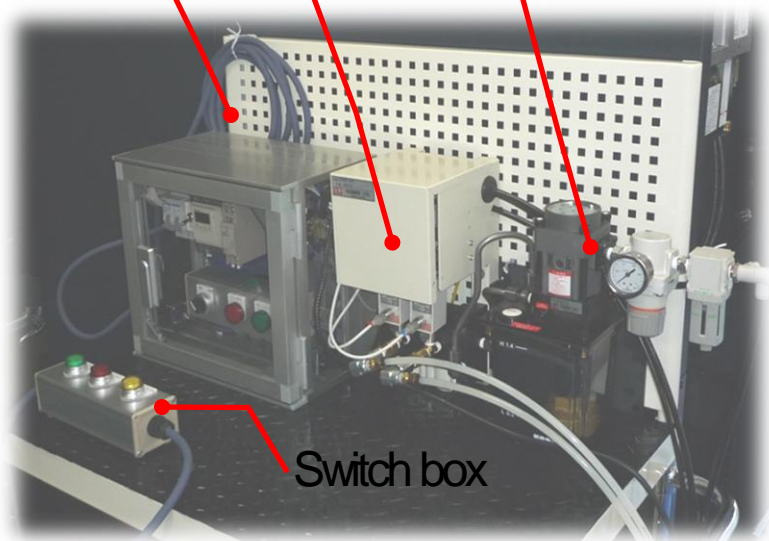

# Specifications

Specification		HSK40A F70S45-A40-64	HSK63A F100S65-A63-89	HSK100A F140S100-A100-139
Clamping force (at 3.5MPa/hyd.)	kN	6.2	2.4	5.5
Unclamping force (at 3.5MPa/hyd.)	kN	1.8	5.3	1.5
Stroke (total)	mm	13	14	18
Stroke (clamping)	mm	7	8	12
Stroke (ejection)	mm	0.5	0.5	0.8
Weight	kg	1.1	3.1	9.7



# Dimension (Hydraulic Clamping Head)

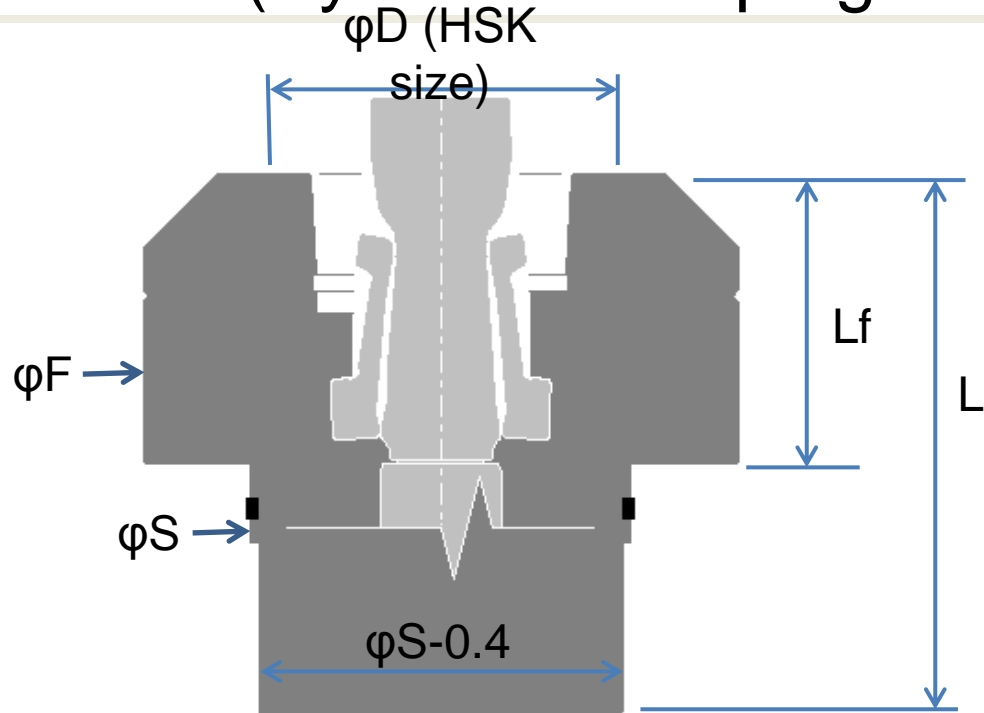

Dimension	HSK40A F70S45-A40-64	HSK63A F100S65-A63-89	HSK100A F140S100-A100-139
D	40	63	100
F	70	100	140
S/g6	45	65	100
L	64	89	139
Lf	35	50	80

# Mounting Block

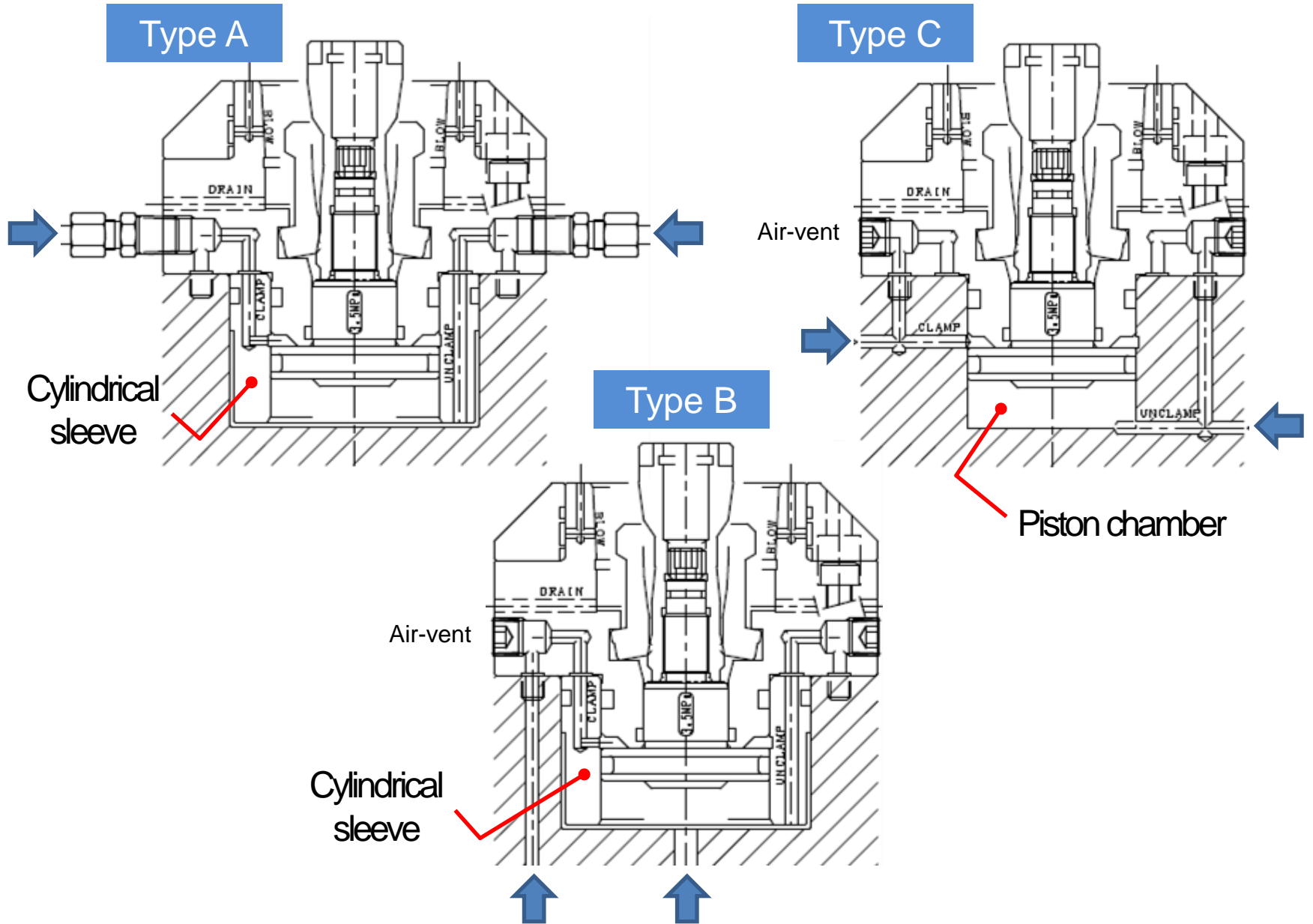

# Cabling/hydraulic & pneumatic (5axis, Rotary table)

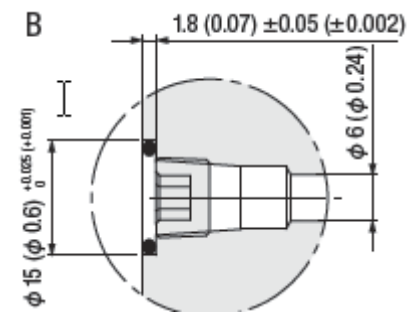
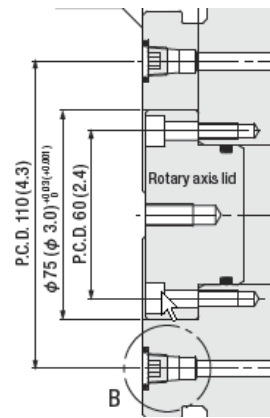
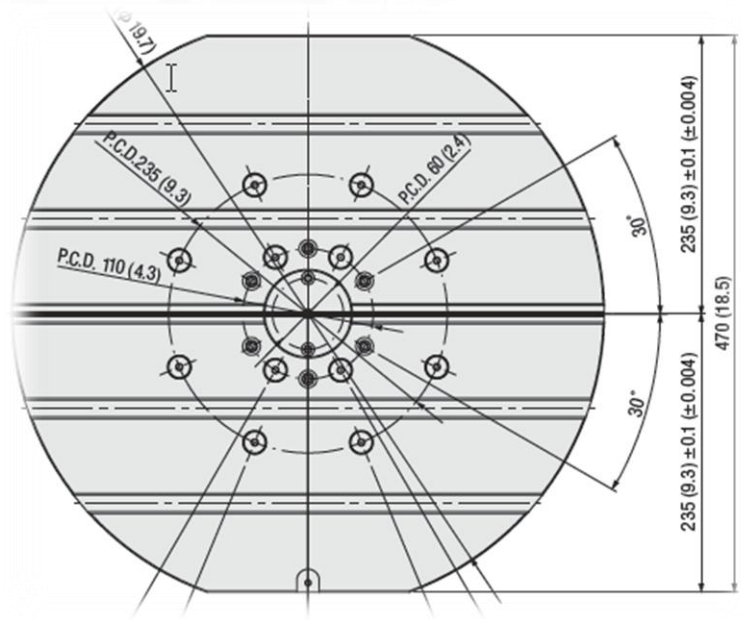
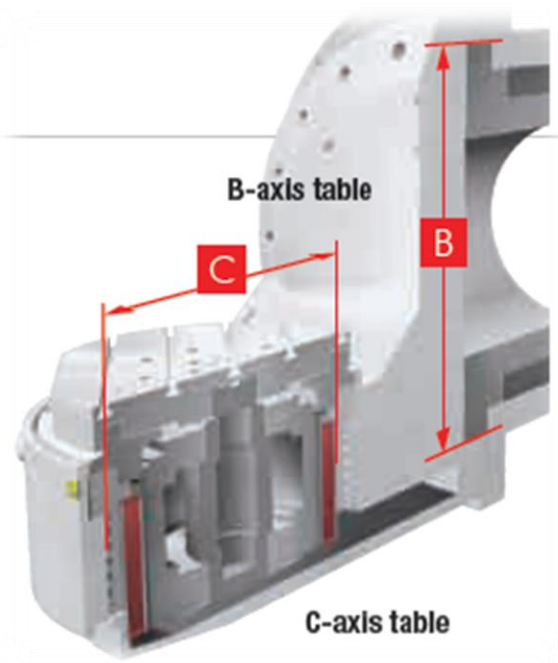
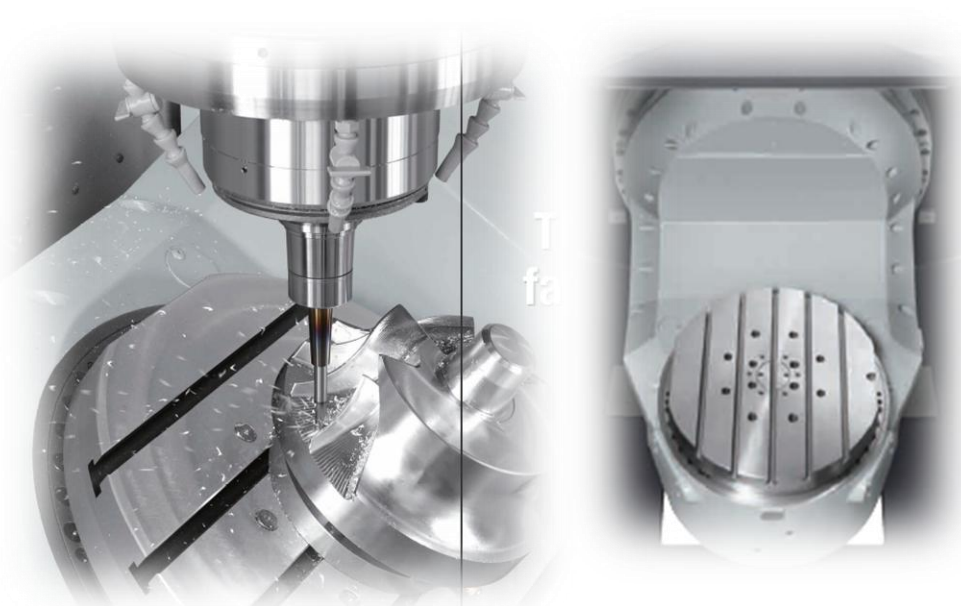

# Cabling/hydraulic & pneumatic ( Rotary table)

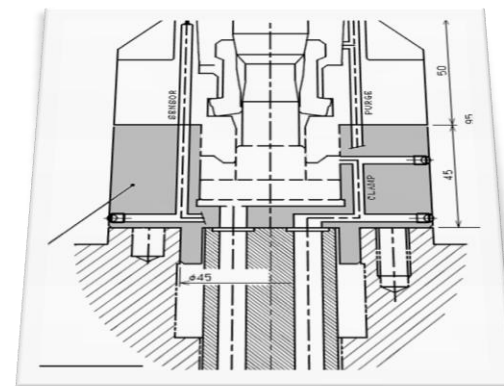
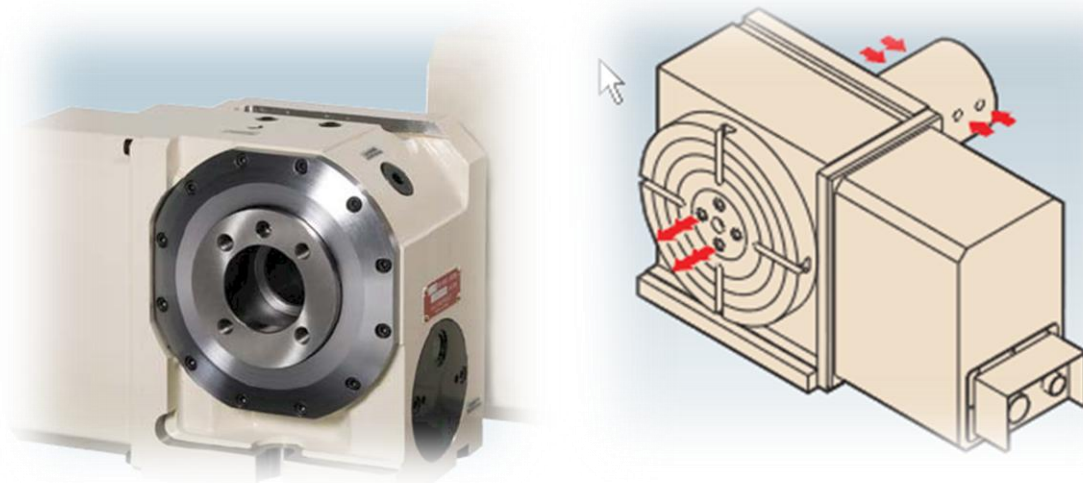

Rotary joint (front supply)

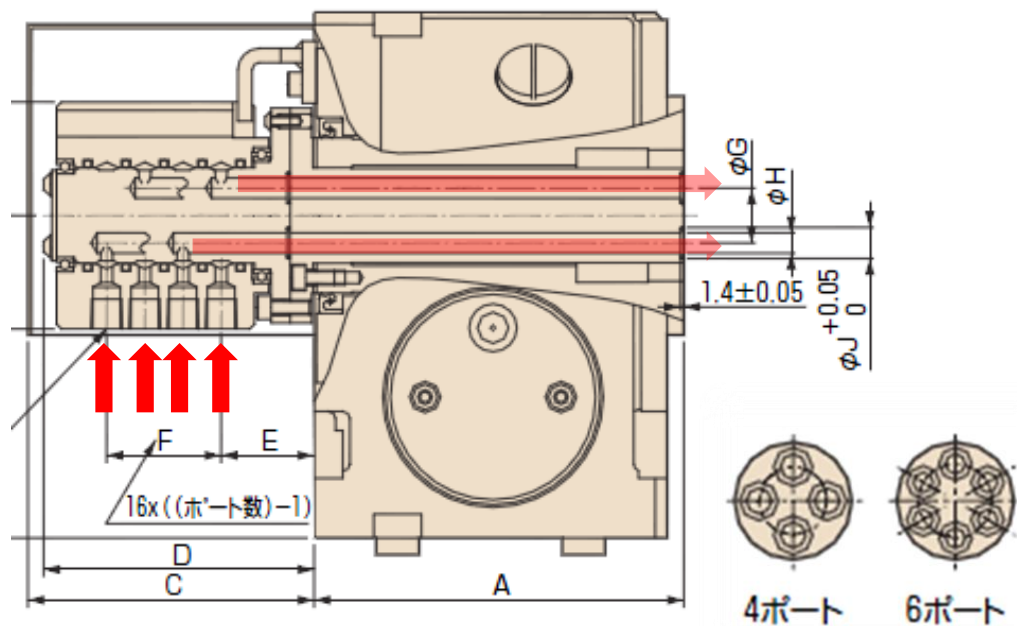

Rotary joint

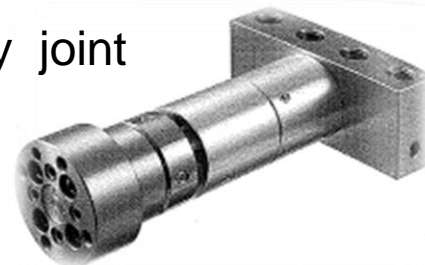

# Cabling/hydraulic & pneumatic (other examples)

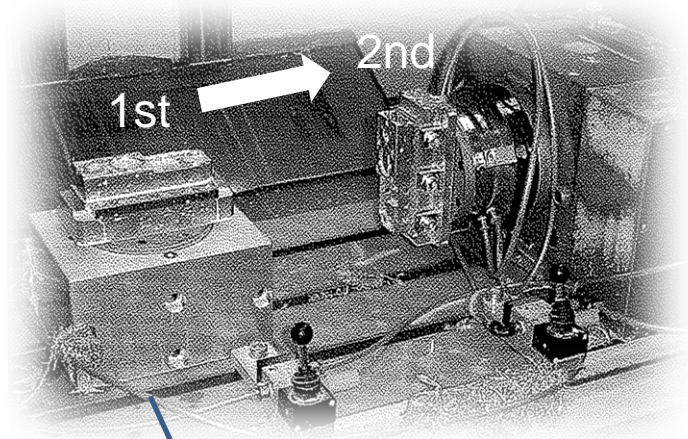

Tube(pneumatic)



Tube(pneumatic)

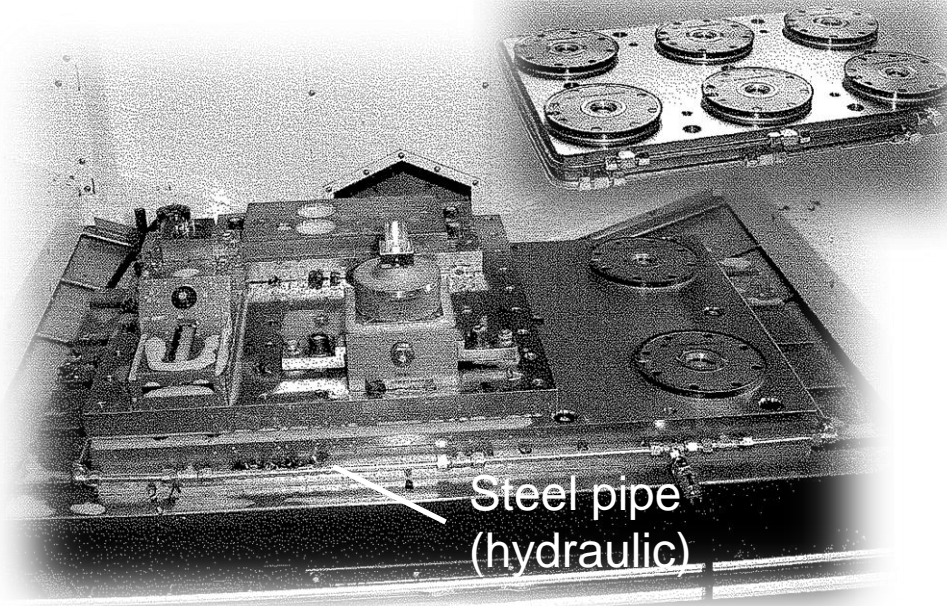

Steel pipe  
(hydraulic)



Distributor (mounting block)