



# Selection Guide for CNC Rotary Tables ...



Bluetooth®

pl

HYUNDAI  
**wia**

10/2018 | EN



... for F-, i-CUT- and KF-series

CNC rotary tables for economical manufacturing:  
pL LEHMANN has suitable and rational solutions for  
nearly every industry

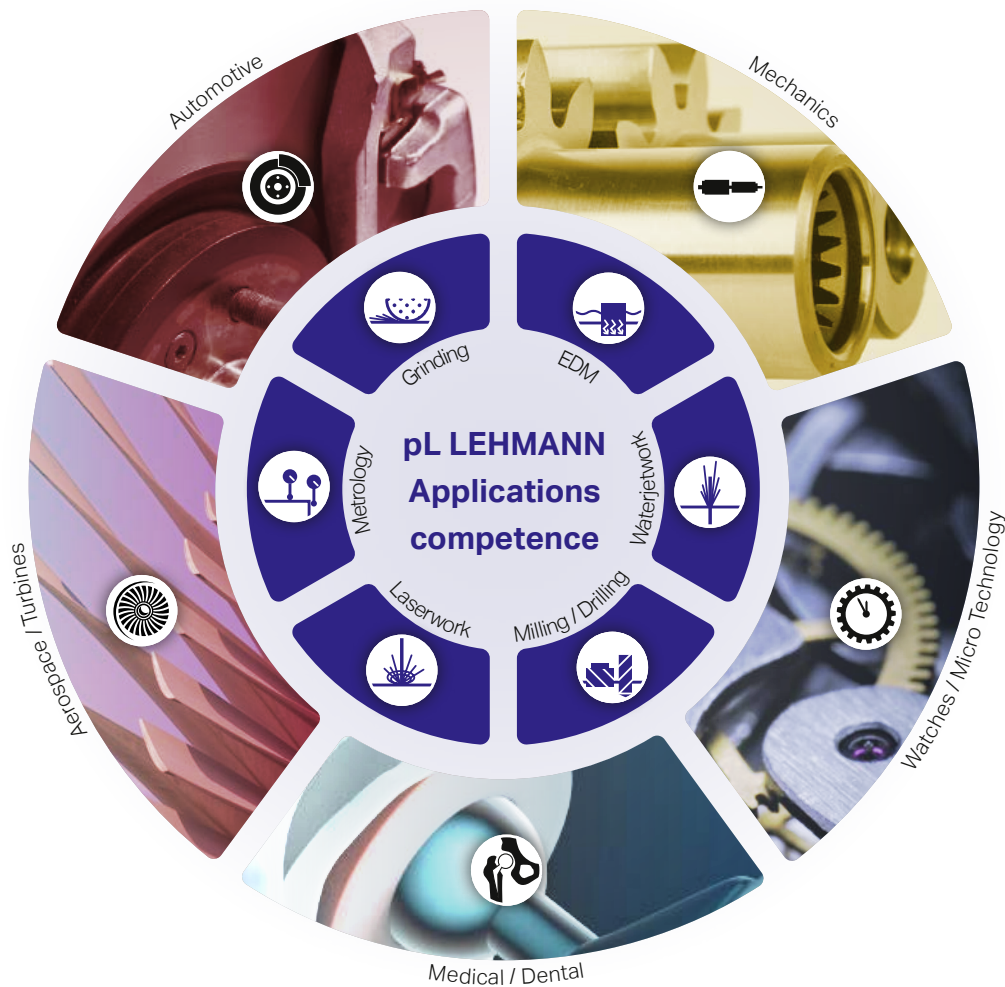

pL rotary tables in use: on over **40** different machine brands  
and over **160** different machine models.

pL competence: Integration in **all known** CNC control systems  
(Fanuc, Siemens, Heidenhain, Haas, Winmax, Mitsubishi, Brother,  
Mazatrol, Okuma ...), for new machines as well as for retrofits



**NEW**  
up to +30 %

Up to 210 rpm  
up to 0.21 sec / 90°

Extended travel in  
Z- and X-direction

High spindle load,  
heavy-duty bearing

**High speed**

**More space**

**Heavy duty**

## E-Series



**Rotary tables suitable for simultaneous operation!**

### Save energy

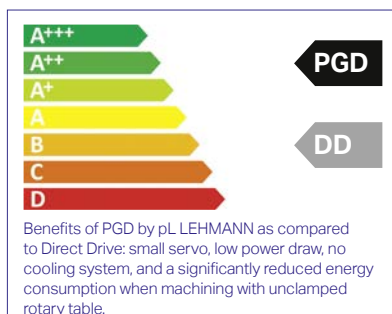

**Energy label at the left**  
An intuitive rating as consumption greatly depends on usage, and without any liability assumed, following the directives on energy labelling

**See main catalog for more features**

**NEW**  
up to +30 %

**High torque**

Feed torque up to  
**850 Nm** (provisional)

**Adaptability**

Multifunctional  
spindle HSK

**Precision**

On the workpiece, as  
precise as **2 μm / 100 mm**

**NEW**  
up to +150%

Pneum. clamping  
up to 7,000 Nm

**High clamp**

Large parts  
up to  $\varnothing$  500

**Big size**

PGD backlash-free  
long-life gear unit

**No backlash**



## T-Series



**All base plates  
made of steel**

**NEW**

with integrated hole pattern for  
slot spacing of 100 and 125 mm,  
integrated alignment system  
**lineFIX** for lengthwise or cross-  
wise clamping.

## M-Series



**NEW**

Bluetooth®

**Connectivity**

Wireless monitoring,  
for operation & service

**No adjust**

Load change without  
parameter adjustment

**Less cost**

No cooling system,  
no hydraulics



F400 (VM)

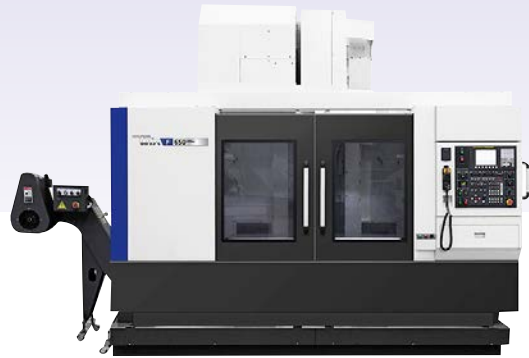

F650PLUS



i-CUT400M



KF4600

## A word from Hyundai WIA:

**«From unique design to production and after-sales service, Hyundai WIA's machine tools are products which provide higher productivity and higher precision**

Since its formation, Hyundai WIA has been steadily accumulating know-how in the precision machine industry. From a position of leadership in its domestic market, the company is spreading its wings to serve the global market.»

The right machine/rotary table combination for economical production: this Selection Guide helps you make the right selection

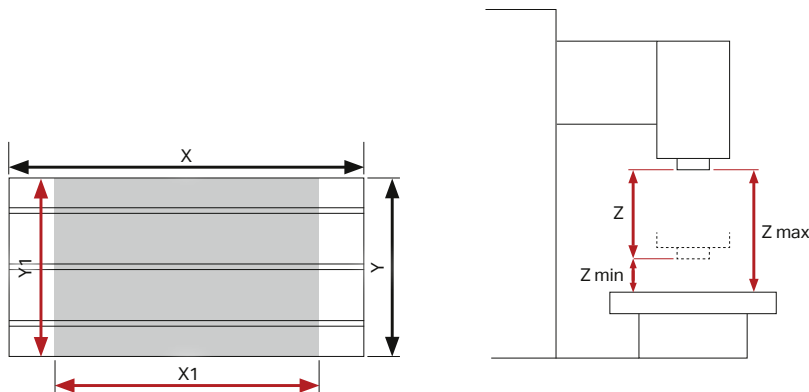

	Table diameter [mm]		Permissible overhang *	Traverse stroke [mm]					Table load ** max [kg]
	X	Y		X1	Y1	Z	Zmin	Zmax	
F400 (VM)	1'000	460	10%	800	460	520	130	650	600
F410D	650	410	10%	570	410	580	197	777	250
F500(PLUS/50)	1'200	500	10%	1'060	510	635	150	785	800
F500D	700	500	10%	600	460	570	200	770	350
F500VM	1'200	550	10%	1'100	550	520	150	670	800
F510B	1'200	500	10%	1'100	510	635	150	785	800
F550M	1'200	550	10%	1'100	550	520	150	670	800
F600B	1'600	600	10%	1'150	600	600	180	780	1'000
F600D	900	650	10%	800	600	600	200	800	400
F650(PLUS/50)	1'600	650	10%	1'400	660	635	150	785	1'300
F650VM	1'400	670	10%	1'300	670	635	150	785	1'000
F660M	1'600	650	10%	1'400	660	635	150	785	1'300
F850	1'800	850	10%	1'600	850	580	150	730	1'000
i-CUT400M/T	650	400	40%	500	400	330	150	480	300
i-CUT400TD	650	400	10%	520	400	330	150	480	250
i-CUT450T	850	460	40%	700	450	330	150	480	300
KF4600	1'050	460	10%	900	460	520	150	670	600
KF4600C	1'050	460	10%	900	460	520	350	870	600
KF5600	1'250	560	10%	1'100	560	520	150	670	1'000
KF5600C	1'250	560	10%	1'100	560	520	450	970	1'000
KF6700	1'500	670	10%	1'300	670	635	150	785	1'300
KF6700C	1'500	670	10%	1'300	670	635	450	1'085	1'300

\* The recommended rotary tables can overhang the machine table by so many % (e.g. 10 % means: the rotary table length can be greater than dimension Y or X by max. 10 % of the machine width Y with Y-clamping or 10 % of the table length X with X-clamping.)

\*\* The recommended rotary tables do not exceed 50 % of the allowed table load.

### Table explanation for pp. 8–11

	EA-507 X2	EA-510 X2	EA-520 X2	EA-530 X2
F400 (VM)	733	717	691	

Wherever values are listed, the combination is recommended. Empty cells mean that a combination is not possible, because the rotary table is too large, or is not recommended, because the rotary table is disproportionately small or heavier than 50% of the table load.

For further details about the rotary tables, see p. 12 and higher or refer to the main catalog



	EA-507 X2	EA-510 X2	EA-520 X2	EA-530 X2
F400 (VM)	733	717	691	
F410D	443	427	401	
F500(PLUS/50)	963	947	921	892
F500D	483	467	441	412
F500VM	983	967	941	912
F510B	983	967	941	912
F550M	983	967	941	912
F600B	1'208	1'192	1'166	1'137
F600D		667	641	612
F650(PLUS/50)		1'317	1'291	1'262
F650VM			1'141	1'112
F660M		1'317	1'291	1'262
F850				1'462
i-CUT400M/T	408	392	366	
i-CUT400TD	418	402	376	
i-CUT450T	608	592	566	
KF4600	808	792	766	
KF4600C	808	792	766	
KF5600	1'008	992	966	937
KF5600C	1'008	992	966	937
KF6700			1'191	1'162
KF6700C			1'191	1'162

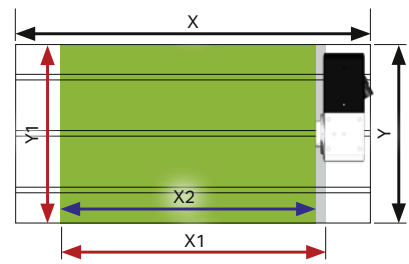

Rotary table installation with pL clamping claws in accordance with the operating manual

## Clamping yokes for EA-type rotary tables

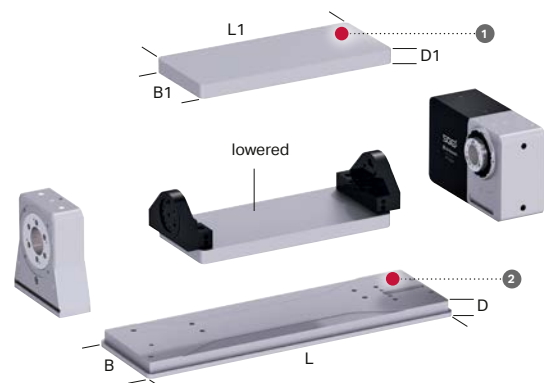

			EA-507		EA-510		EA-520			EA-530	
1 Clamping yokes	Sph	[mm]	190		180		210			218	
	Length L1	[mm]	350	450	500	600	600	700	800	800	1000
	Width B1	[mm]	165		215			270			270
	Thickness D1	[mm]	20		35			40			40
2 Base plates	Length L	[mm]	622	722	785	885	916	1016	1116	1172	1372
	Width B	[mm]	168		248			301			368
	Thickness D	[mm]	30		30			30			38
Weights / moments of inertia (without rotary table, without counter bearing)	Weight (Al)	[kg]	10	12	23	28	40	45	52	on request	
	Weight (steel)	[kg]	29	34	66	80	117	130	152		
	Mom. inert. (Al)	[kgm <sup>2</sup> ]	0.02	0.02	0.06	0.07	0.16	0.17	0.21		
	Mom. inert. (steel)	[kgm <sup>2</sup> ]	0.04	0.05	0.17	0.21	0.46	0.50	0.60		



## Explanations for pp. 8 to 11

The recommendations are for information purposes only. We recommend that you verify the effective dimensions prior to ordering. Modifications on the machine can lead to collisions and affect the dimensions X2 and Y2.



	M2-507	M2-510	M3-507	M3-510
	X2			
F400 (VM)	674			
F410D	384			
F500(PLUS/50)	904	894		
F500D	424	414		
F500VM	924	914	924	
F510B	924	914		
F550M	924	914	924	
F600B	1'149	1'139	1'149	
F600D	624	614	624	614
F650(PLUS/50)	1'274	1'264	1'274	1'264
F650VM	1'124	1'114	1'124	1'114
F660M	1'274	1'264	1'274	1'264
F850	1'474	1'464	1'474	1'464
i-CUT400M/T	349	339		
i-CUT400TD				
i-CUT450T	549	539	549	
KF4600	749			
KF4600C	749			
KF5600	949	939	949	
KF5600C	949	939	949	
KF6700	1'174	1'164	1'174	1'164
KF6700C	1'174	1'164	1'174	1'164

## Y-mounting

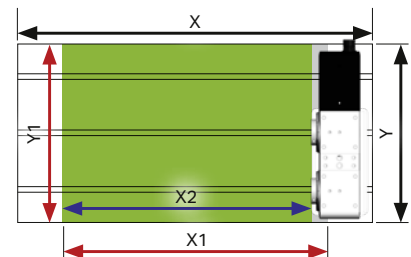

Rotary table installation with pL clamping claws in accordance with the operating manual

	M2-507	M2-510	M3-507	M3-510
	Y2			
F400 (VM)		224	234	224
F410D		174	184	174
F500(PLUS/50)				269
F500D			254	244
F500VM				314
F510B				269
F550M				314
F600B				
F600D				
F650(PLUS/50)				
F650VM				
F660M				
F850				
i-CUT400M/T			174	164
i-CUT400TD	174	164	174	164
i-CUT450T				219
KF4600			234	224
KF4600C			234	224
KF5600				324
KF5600C				324
KF6700				
KF6700C				

## X-mounting

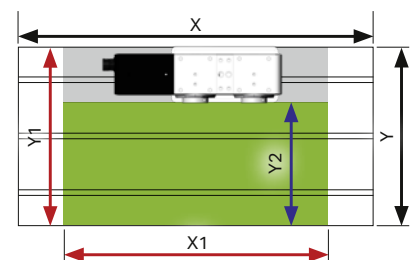

Rotary table installation with pL clamping claws in accordance with the operating manual

## Y-mounting

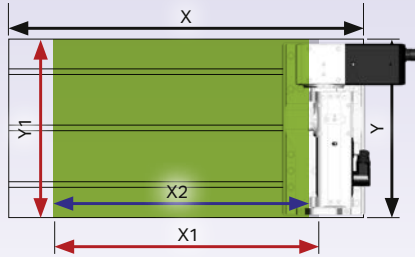

Rotary table installation using hole pattern in base plate



TIP1



TAP1



TOP1.2

	TIP1c TF-507510 X2	TIP2c TF-510520 X2	TIP3c TF-520530 X2	TAP1c T1-507510 X2	TAP2c T1-510520 X2	TAP3c T1-520530 X2	TAP1 T1-507510 X2	TAP2 T1-510520 X2	TAP3 T1-520530 X2	TOP1 T1-507510 X2
F400 (VM)	770									
F410D										
F500(PLUS/50)	1'000	956		960						
F500D	520	476		480						
F500VM	1'020	976		980	960		980			
F510B	1'020	976		980						
F550M	1'020	976		980	960		980			
F600B	1'245	1'201	1'181	1'205	1'185		1'205	1'185		1'205
F600D	720	676	656	680	660		680	660		680
F650(PLUS/50)	1'370	1'326	1'306	1'330	1'310	1'276	1'330	1'310		1'330
F650VM	1'220	1'176	1'156	1'180	1'160	1'126	1'180	1'160		1'180
F660M	1'370	1'326	1'306	1'330	1'310	1'276	1'330	1'310		1'330
F850	1'570	1'526	1'506	1'530	1'510	1'476	1'530	1'510	1'476	1'530
i-CUT400M/T	445	401		405						
i-CUT400TD										
i-CUT450T	645	601		605	585		605			605
KF4600	845									
KF4600C	845									
KF5600	1'045	1'001		1'005	985		1'005			1'005
KF5600C	1'045	1'001		1'005	985		1'005			1'005
KF6700	1'270	1'226	1'206	1'230	1'210	1'176	1'230	1'210		1'230
KF6700C	1'270	1'226	1'206	1'230	1'210	1'176	1'230	1'210		1'230

	TOP2 T1-510520 X2	TOP3 T1-520530 X2	TAP1c.2 T1-507510 X2	TAP2c.2 T1-510520 X2	TAP3c.2 T1-520530 X2	TAP1.2 T1-507510 X2	TAP2.2 T1-510520 X2	TAP3.2 T1-520530 X2	TOP1.2 T2-507510 X2	TOP2.2 T2-510520 X2	TOP3.2 T2-520530 X2
F400 (VM)											
F410D											
F500(PLUS/50)											
F500D											
F500VM											
F510B											
F550M											
F600B			1'205								
F600D	660		680		680						
F650(PLUS/50)	1'310		1'330		1'330						
F650VM	1'160		1'180		1'180						
F660M	1'310		1'330		1'330						
F850	1'510	1'476	1'530	1'510		1'530	1'510		1'530	1'510	
i-CUT400M/T											
i-CUT400TD											
i-CUT450T											
KF4600											
KF4600C											
KF5600											
KF5600C											
KF6700	1'210		1'230		1'230						
KF6700C	1'210		1'230		1'230						

## X-mounting

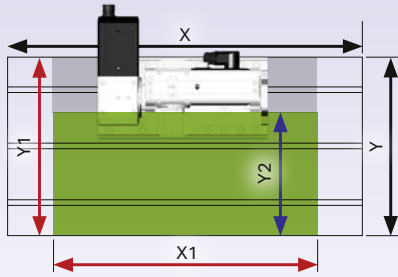

Rotary table installation using hole pattern in base plate



	TIP1c TF-507510 Y2	TIP2c TF-510520 Y2	TIP3c TF-520530 Y2	TAP1c T1-507510 Y2	TAP2c T1-510520 Y2	TAP3c T1-520530 Y2	TAP1 T1-507510 Y2	TAP2 T1-510520 Y2	TAP3 T1-520530 Y2	TOP1 T1-507510 Y2
F400 (VM)		286	266	290	270	236	290	270	236	290
F410D	280	236		240			240			240
F500(PLUS/50)			311			281		315	281	335
F500D					290		310	290		310
F500VM			356			326		360	326	380
F510B			311			281		315	281	335
F550M			356			326		360	326	380
F600B										
F600D										
F650(PLUS/50)										
F650VM									446	
F660M										
F850										
i-CUT400M/T					210		230			230
i-CUT400TD	270	226		230			230			230
i-CUT450T										
KF4600		286	266		270	236	290	270	236	290
KF4600C		286	266		270	236	290	270	236	290
KF5600			366			336		370	336	
KF5600C			366			336		370	336	
KF6700									446	
KF6700C									446	

	TOP2 T1-510520 Y2	TOP3 T1-520530 Y2	TAP1c.2 T1-507510 Y2	TAP2c.2 T1-510520 Y2	TAP3c.2 T1-520530 Y2	TAP1.2 T1-507510 Y2	TAP2.2 T1-510520 Y2	TAP3.2 T1-520530 Y2	TOP1.2 T2-507510 Y2	TOP2.2 T2-510520 Y2	TOP3.2 T2-520530 Y2
F400 (VM)	270		290	270		290	270		290	270	
F410D			240			240					
F500(PLUS/50)	315	281	335	315	281	335	315	281	335	315	281
F500D	290		310			310			310		
F500VM	360	326	380	360	326	380	360	326	380	360	326
F510B	315	281	335	315	281	335	315	281	335	315	281
F550M	360	326	380	360	326	380	360	326	380	360	326
F600B		376		410	376		410	376		410	376
F600D				435			435		455	435	
F650(PLUS/50)		431		465	431		465	431		465	431
F650VM		446		480	446		480	446	500	480	446
F660M		431		465	431		465	431		465	431
F850					626			626			626
i-CUT400M/T			230			230					
i-CUT400TD			230			230					
i-CUT450T			285	265		285			285		
KF4600	270		290	270	236	290	270		290	270	
KF4600C	270		290	270	236	290	270		290	270	
KF5600	370	336	390	370	336	390	370	336	390	370	336
KF5600C	370	336	390	370	336	390	370	336	390	370	336
KF6700		446		480	446		480	446		480	446
KF6700C		446		480	446		480	446		480	446



Very good accessibility, even with short tools

More space for workpieces and fixtures

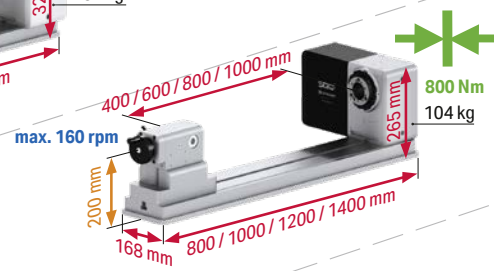
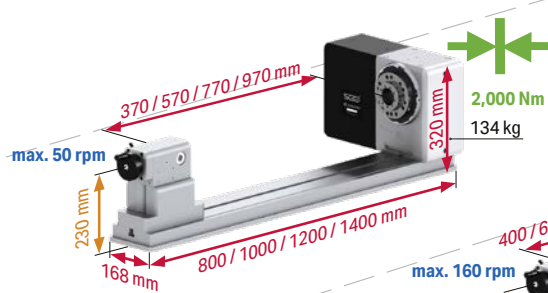
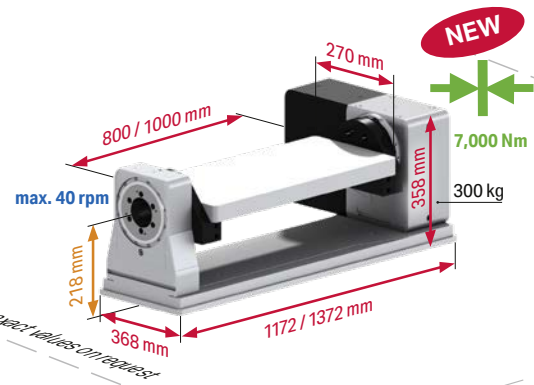
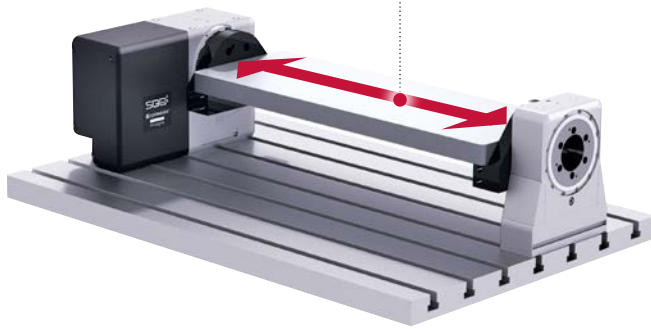

530

520

51x

50x

SIZE

### News in brief

1. High speed up to 210 rpm
2. Feed torque up to 850 Nm (tentative)
3. Steel base plates with hole pattern (suitable for slot spacing of 100 and 125 mm)
4. Cycle time 90° as fast as 0.21 sec.

 Weight data represent the standard load; higher weights possible, but require modification of rotational speed, acceleration and jerk limitation.

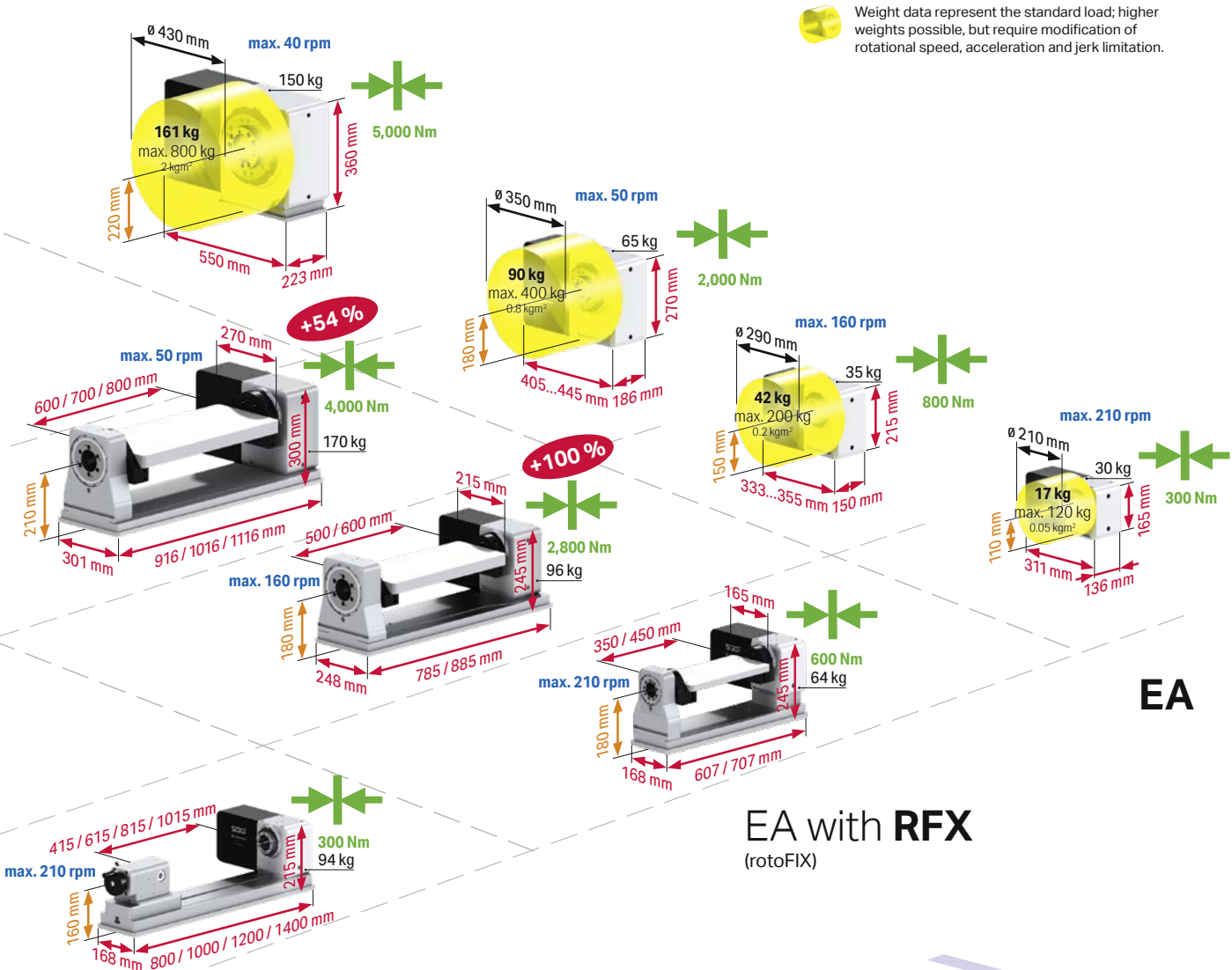

EA

EA with **RFX**  
(rotoFIX)

EA with **LFX**  
(longFLEX)

MODEL

- 50x 507 (standard) or 508 (high speed)
- 51x 510 (standard) or 511 (high speed)
- EA single-axis, single-spindle CNC rotary table
- rotoFIX modular clamping yoke system
- longFLEX modular shaft clamping system

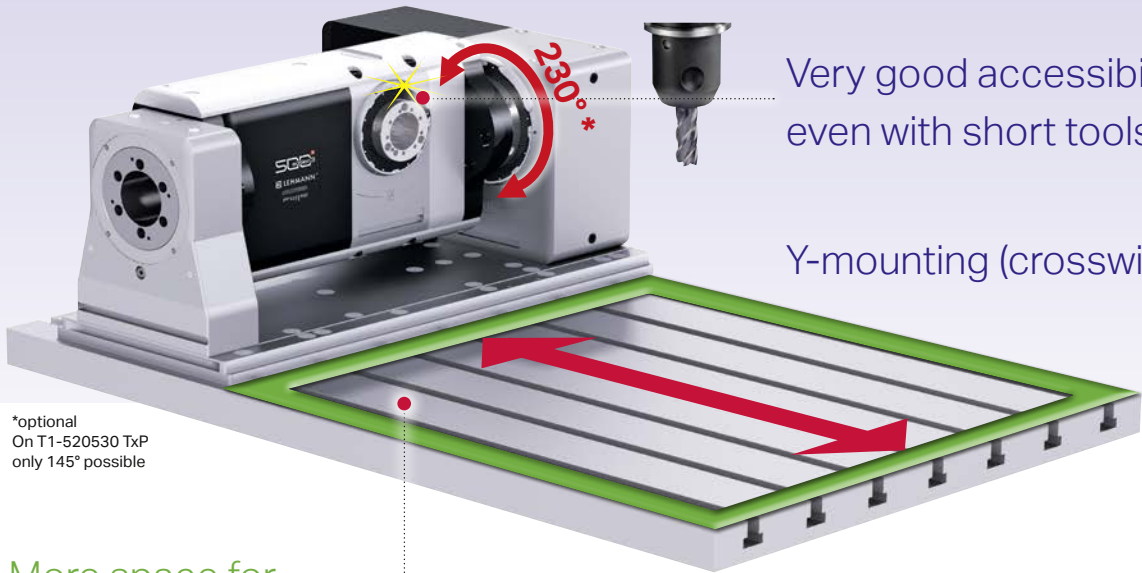

Very good accessibility, even with short tools

Y-mounting (crosswise)

\*optional  
On T1-520530 TxP  
only 145° possible

More space for workpiece and fixtures

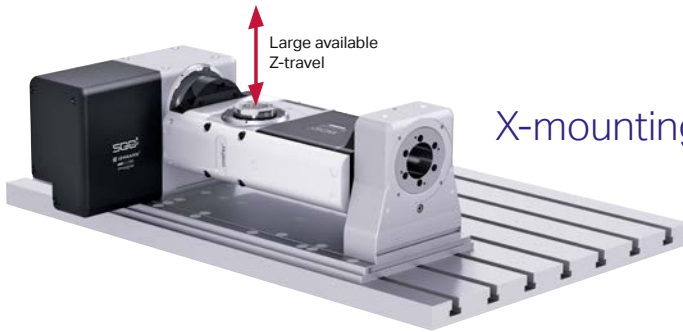

X-mounting (lengthwise)

T1

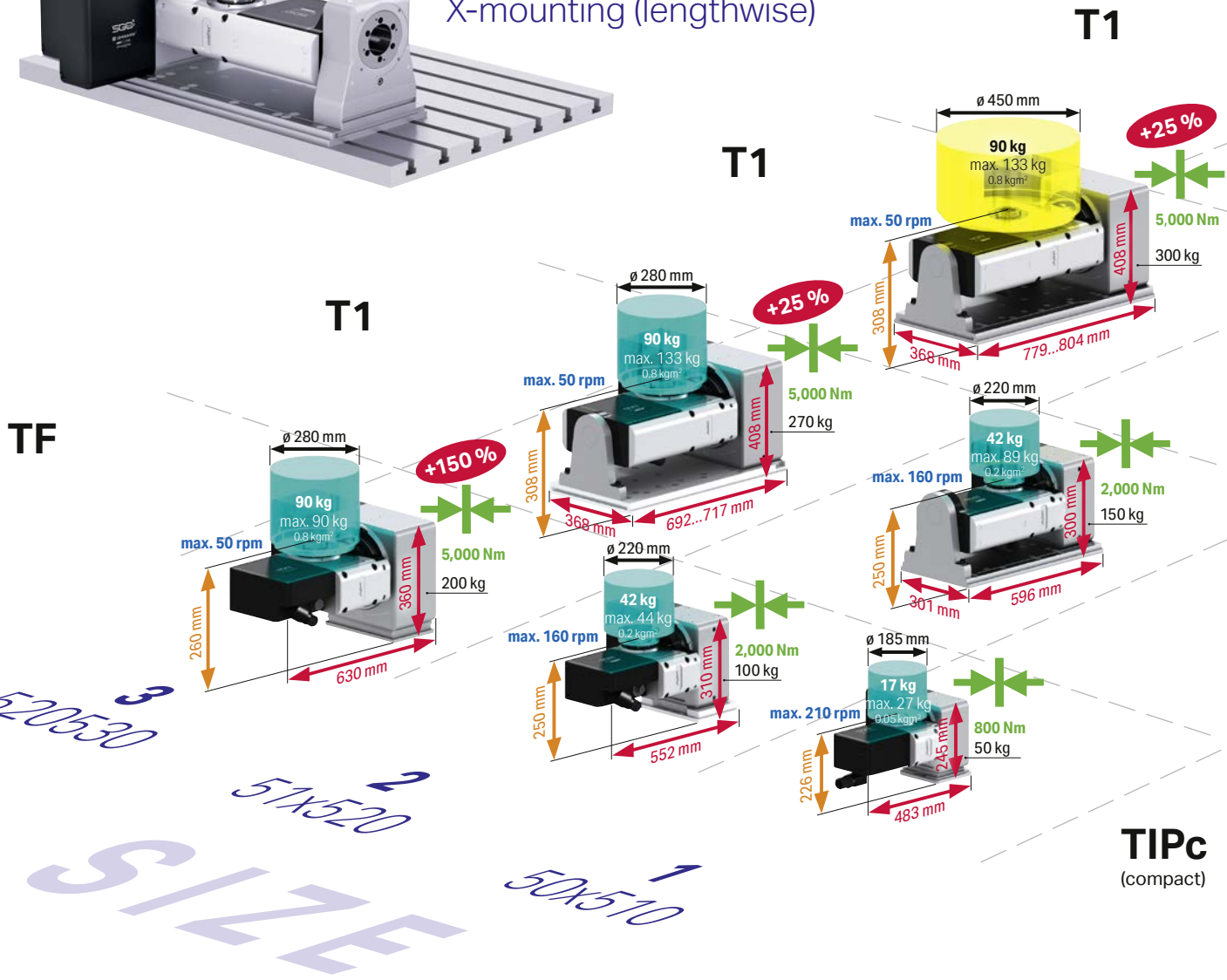

### News in brief

1. Up to 150% higher clamping torque in tilting axis
2. Fewer variant – more solution
3. Larger workpiece  $\varnothing$  possible
4. Spatially optimized arrangement of the dividing axis

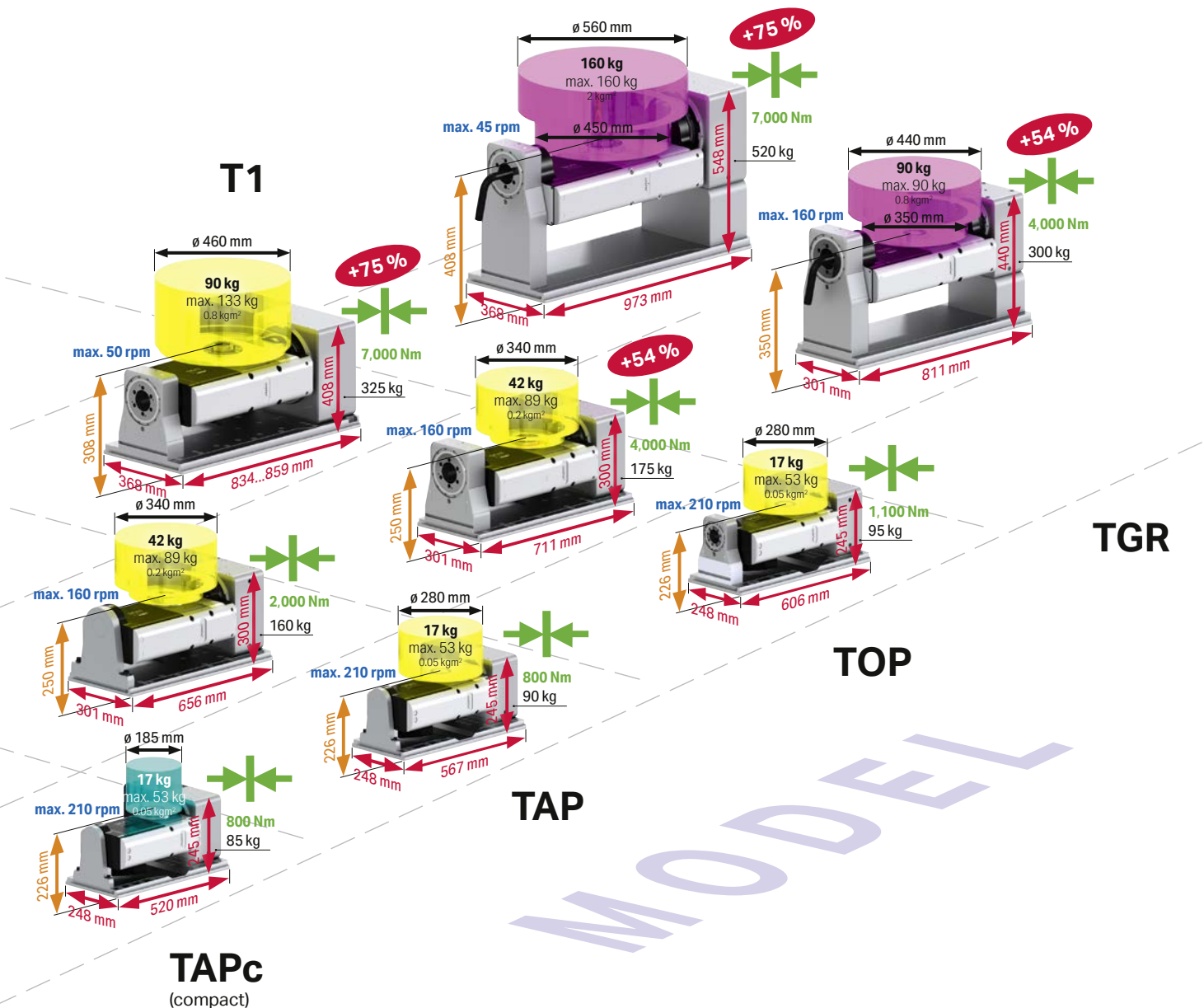

Weight data represent the standard load; higher weights possible, but require modification of rotational speed, acceleration and jerk limitation.

50x510	508510 (standard) or 508510 (high speed)
51x520	510520 (standard) or 511520 (high speed)
TIPc	Two-axis rotary table, no counter bearing, compact
TAPc	Two-axis rotary table, with supporting bearing, compact
TAP	Two-axis rotary table, with supporting bearing
TOP	Two-axis rotary table, with clamped counter bearing
TGR	Two-axis rotary table, with clamped counter bearing, specifically for grinding applications



More space for workpiece and fixtures

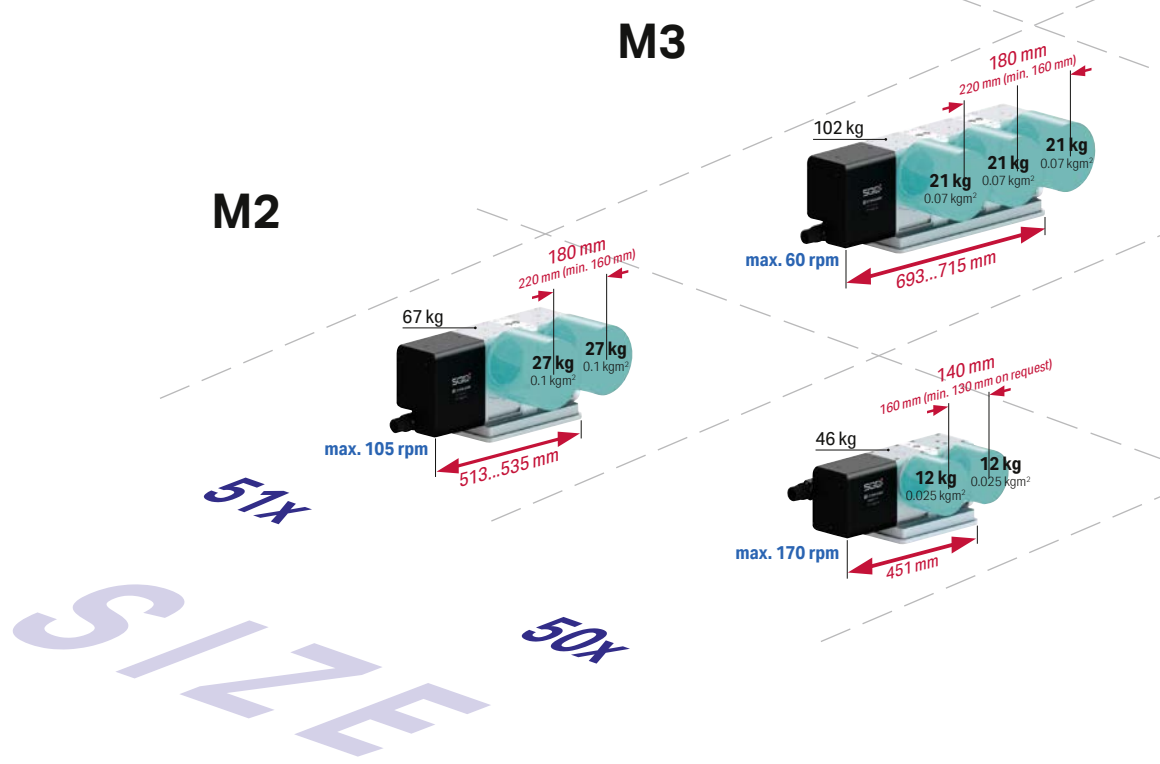



### News in brief

1. Up to **54 %** higher clamping torque in tilting axis
2. Fewer variant – more solution
3. Spindle distance min. **130 mm**
4. Spatially optimized arrangement of the dividing axis

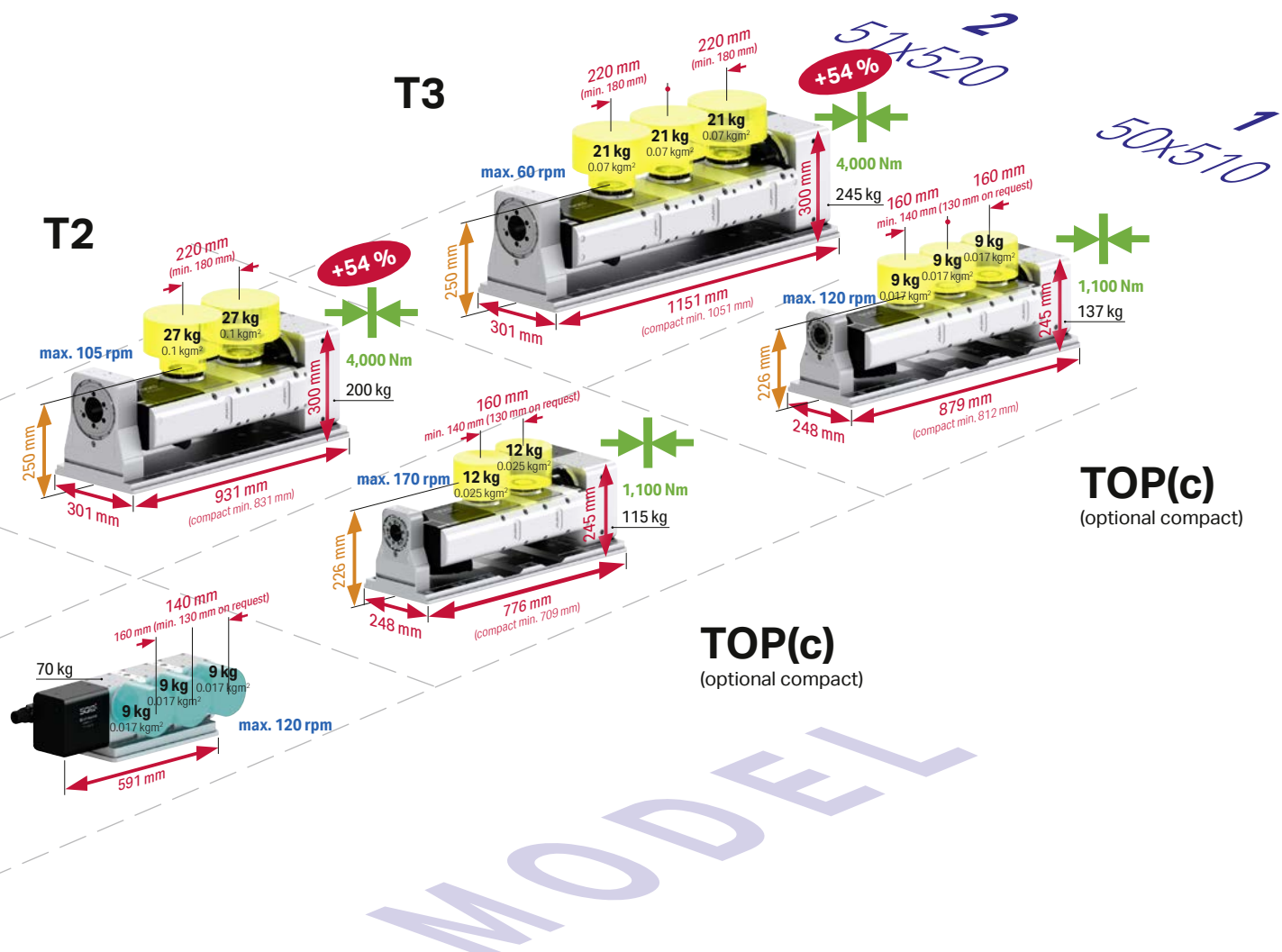

Weight data represent the standard load; higher weights possible, but require modification of rotational speed, acceleration and jerk limitation.

- 50x 507 (standard) or 508 (high speed)
- 51x 510 (standard) or 511 (high speed)
- M2 Single-axis, multi-spindle rotary table, 2-position
- M3 Single-axis, multi-spindle rotary table, 3-position
- T2 Two-axis multi-spindle rotary table, 2-position
- T3 Two-axis multi-spindle rotary table, 3-position

Extremely wide assortment for workpiece clamping.  
Standardized interface in front and rear: maximum universality

## Spindle accessories in rear

- + Rotary unions **up to 250 bar**
- + Clamping cylinder **23 kN at 120 bar**
- + Angular position measuring systems **as precise as  $\pm 1$  arcsec**



## Spindle accessories in front



## Tailstock and counter bearing



## ripas zero point clamping system



EA-507 with ripas auto and ripas adapter

## CAPTO clamping (on request)



EA-507 with CAPTO retrofit kit

Present in over 20 countries: from sales consultation to the final service



**Services from A to Z**

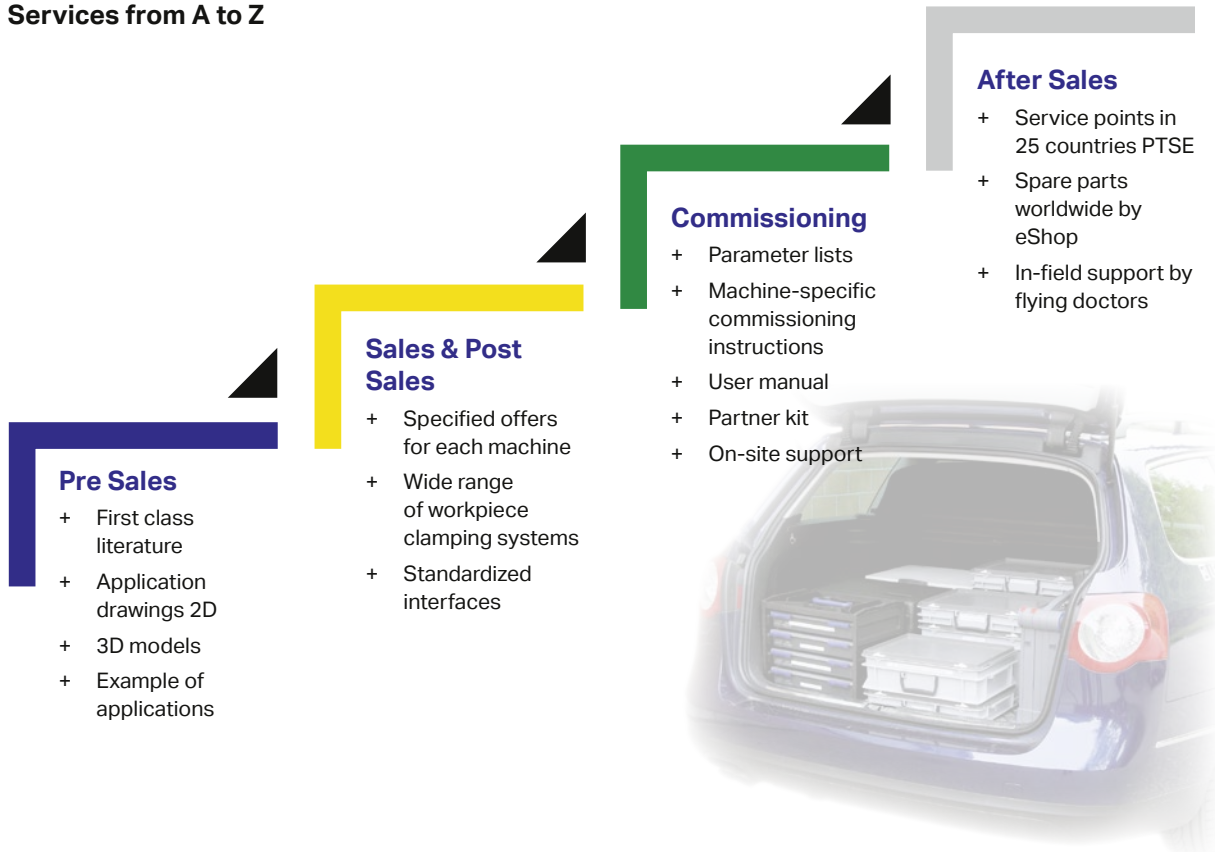

**Increase productivity – Extend lifecycle**

Comprehensive and professional services throughout the product life cycle – maximum availability with consistent quality and high productivity.

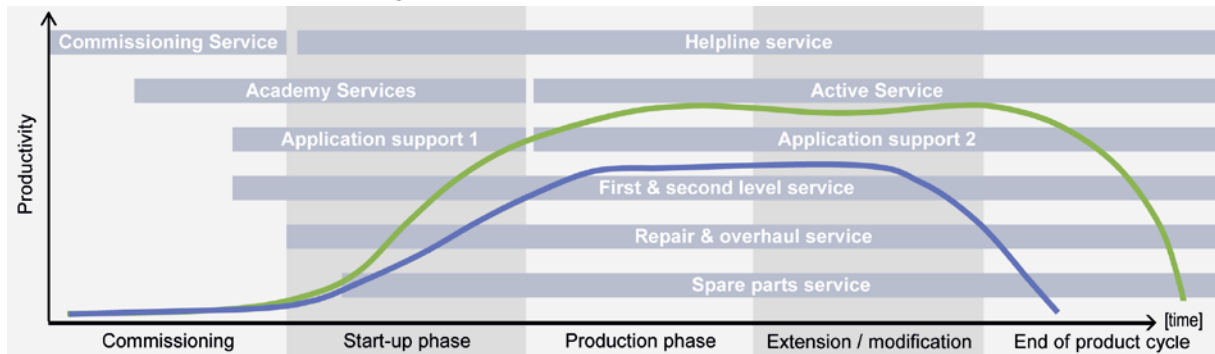

— Productivity with LifeCycle service products from pL LEHMANN  
 — Productivity without service support

For more information please see [www.lehmann-rotary-tables.com](http://www.lehmann-rotary-tables.com).



ROTARY TABLES · PRECISION TECHNOLOGY · SOFTWARE

#### Headquarters

PETER LEHMANN AG  
CH-3552 Bârau  
Phone +41 (0)34 409 66 66  
Fax +41 (0)34 409 66 00  
pls@plehmann.com  
www.lehmann-rotary-tables.com

#### Representatives / Agencies

##### Europe

- Austria
- Benelux
- Czech Republic (vacant)
- Finland
- France
- Germany
- Hungary (vacant)
- Italy
- Norway
- Poland
- Portugal
- Russia
- Slovenia
- Spain
- Sweden
- Turkey
- UK

##### America

- Brazil
- Canada
- Mexico
- USA

##### Asia

- China
- India
- Japan
- Malaysia
- Singapore
- South Korea
- Taiwan
- Thailand
- Vietnam

##### Africa

- South Africa

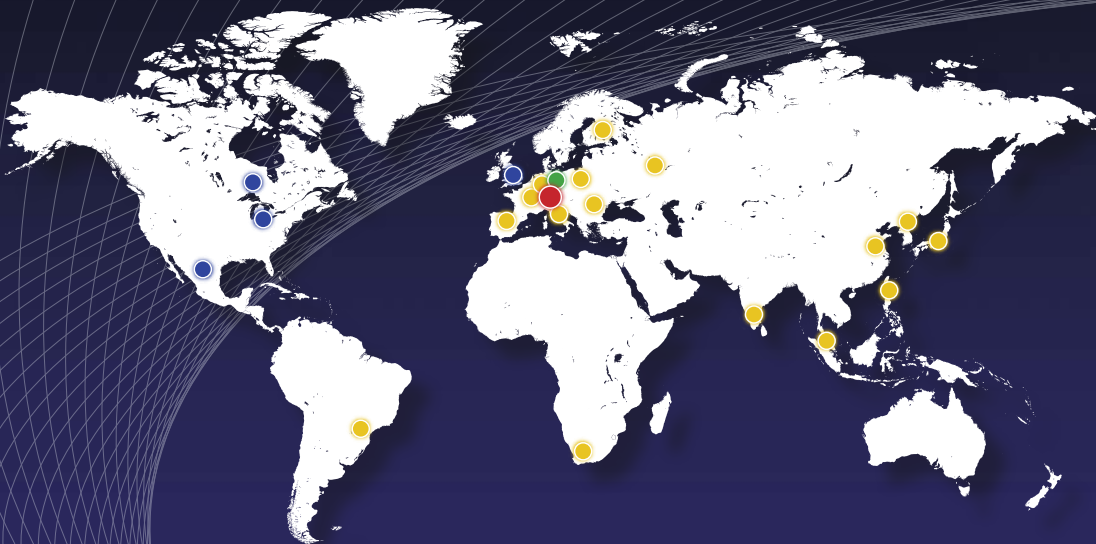

● Headquarters    ● direct sales partner    ● pL Solutions® partner    ● value added reseller & partner

More information (address, telephone number...) at [www.lehmann-rotary-tables.com](http://www.lehmann-rotary-tables.com)