



# Selection Guide for CNC Rotary Tables ...



Bluetooth®

pl



10/2018 | EN



... for HIT-, SIRIUS- and VESTA-series

CNC rotary tables for economical manufacturing:  
pL LEHMANN has suitable and rational solutions for  
nearly every industry

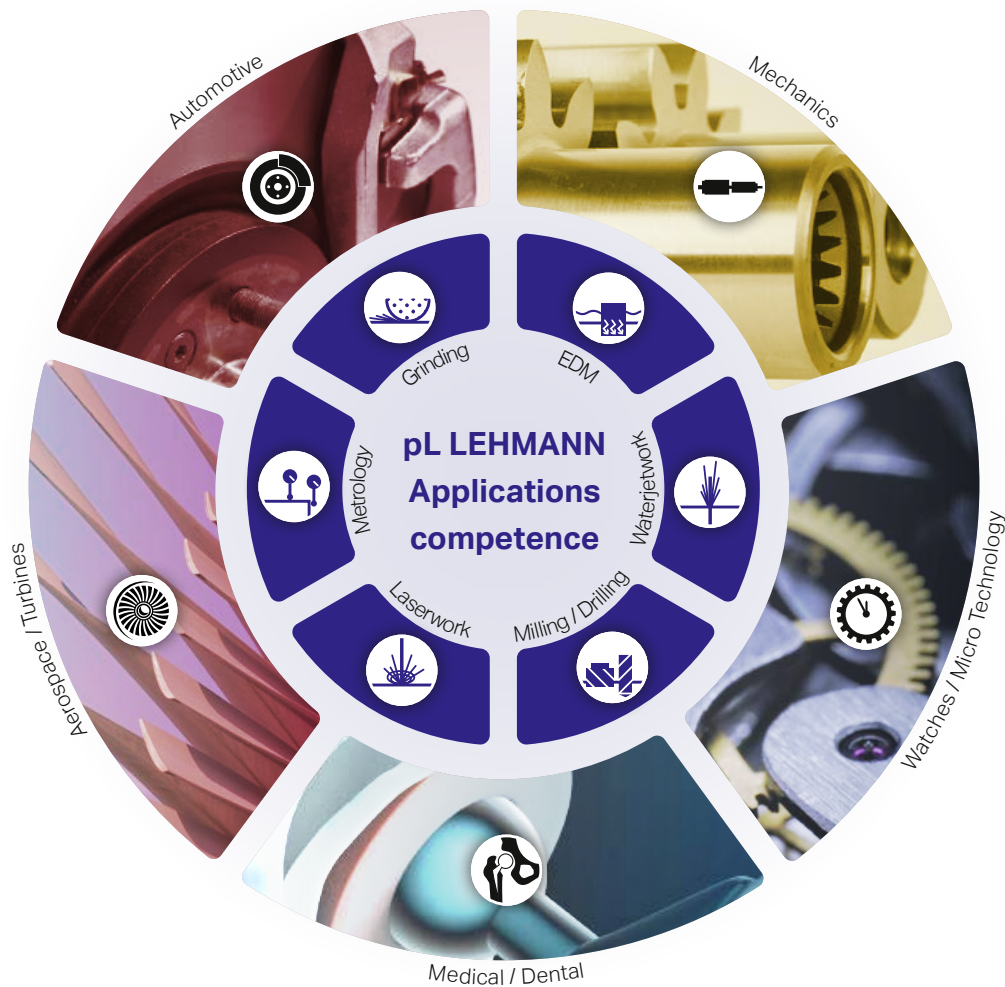

pL rotary tables in use: on over **40** different machine brands  
and over **160** different machine models.

pL competence: Integration in **all known** CNC control systems  
(Fanuc, Siemens, Heidenhain, Haas, Winmax, Mitsubishi, Brother,  
Mazatrol, Okuma ...), for new machines as well as for retrofits

Professional products from professional partners:  
 HWACHEON and pL LEHMANN provide  
 first-class service to common customers

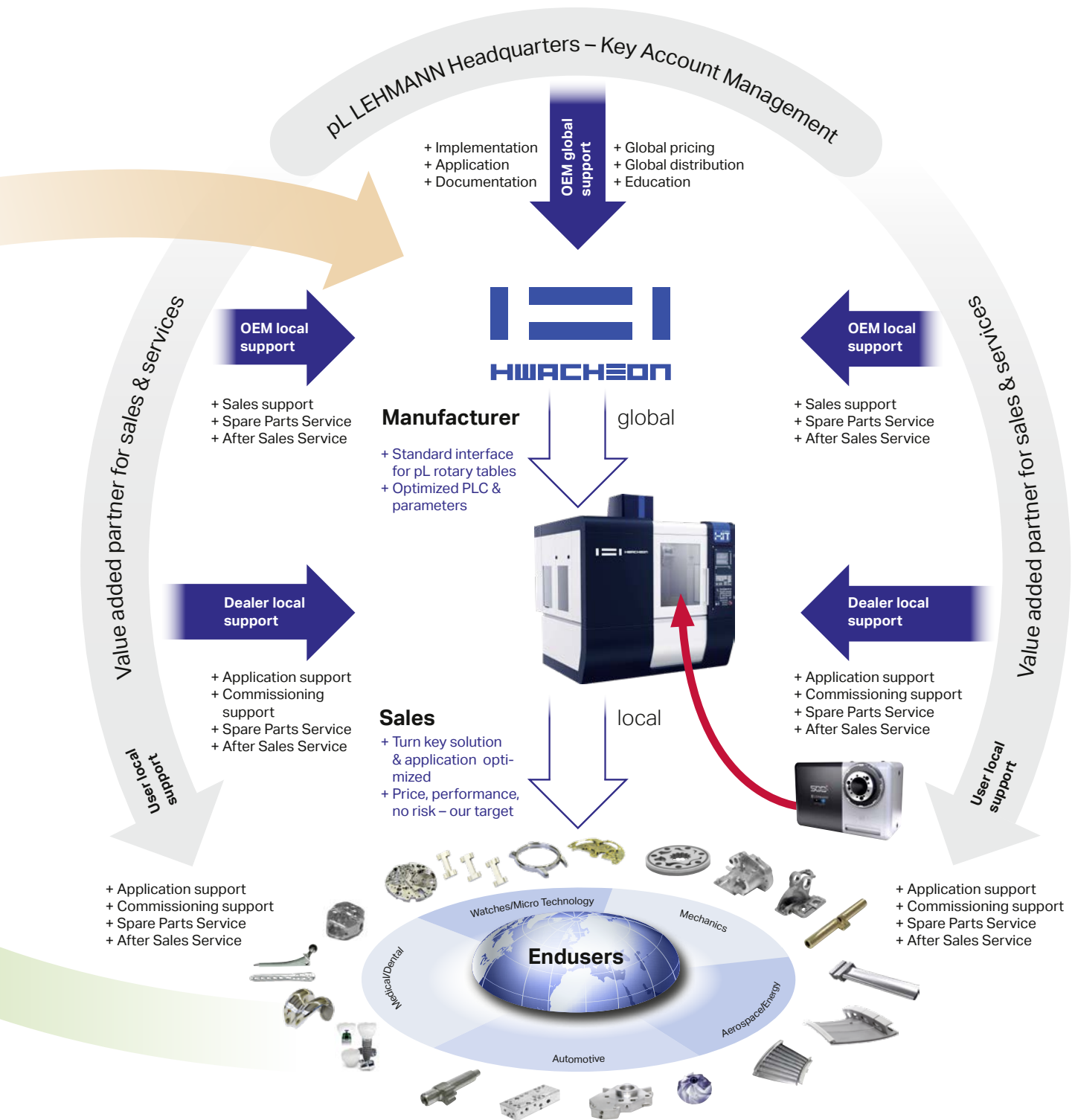

**NEW**  
up to +30 %

Up to 210 rpm  
up to 0.21 sec / 90°

Extended travel in  
Z- and X-direction

High spindle load,  
heavy-duty bearing

**High speed**

**More space**

**Heavy duty**

## E-Series



**Rotary tables suitable for simultaneous operation!**

### Save energy

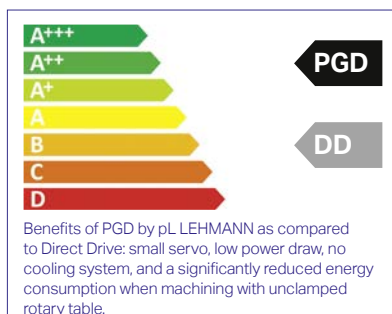

**Energy label at the left**  
An intuitive rating as consumption greatly depends on usage, and without any liability assumed, following the directives on energy labelling

**See main catalog for more features**

**NEW**  
up to +30 %

**High torque**

Feed torque up to  
**850 Nm** (provisional)

**Adaptability**

Multifunctional  
spindle HSK

**Precision**

On the workpiece, as  
precise as **2 µm / 100 mm**

**NEW**  
up to +150%

Pneum. clamping  
up to 7,000 Nm

**High clamp**

Large parts  
up to  $\varnothing$  500

**Big size**

PGD backlash-free  
long-life gear unit

**No backlash**

## T-Series



**All base plates  
made of steel**

**NEW**

with integrated hole pattern for  
slot spacing of 100 and 125 mm,  
integrated alignment system  
**lineFIX** for lengthwise or cross-  
wise clamping.

## M-Series



**NEW**

**Connectivity**

Wireless monitoring,  
for operation & service

**No adjust**

Load change without  
parameter adjustment

**Less cost**

No cooling system,  
no hydraulics



HIT-400L



SIRIUS-UL+



VESTA-1000+

## A word from HWACHEON:

**«HWACHEON means to grow and advance with the clients**

HWACHEON is the industry-leading name in machine tools. In response to your trust, HWACHEON will continue to deliver the best products and services.»

## HWACHEON's vision

HWACHEON's business is machining engineering, and all other related business.



In partnership, HWACHEON will build trust with Clients.

HWACHEON's clients include not only those who use HWACHEON's products, but also those who are within the company and HWACHEON's shareholders.







## Explanations for pp. 8 to 11

The recommendations are for information purposes only. We recommend that you verify the effective dimensions prior to ordering. Modifications on the machine can lead to collisions and affect the dimensions X2 and Y2.



	M2-507	M2-510	M3-507	M3-510
	X2			
HIT-360D	294	284		
HIT-400	334	324		
HIT-400L	524	514		
SIRIUS-UL+	899	889	899	
SIRIUS-UM	574	564		
SIRIUS-UX	1'349	1'339	1'349	1'339
SIRIUS-UZ	899	889	899	
VESTA 500T	394	384		
VESTA 850B	724	714	724	
VESTA 610D	404			
VESTA 660				
VESTA-1000	824	814		
VESTA-1050B	874	864	874	
VESTA-1300	1'149	1'139	1'149	1'139

### Y-mounting

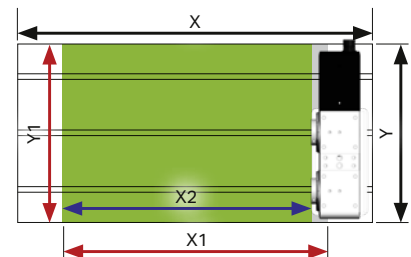

Rotary table installation with pL clamping claws in accordance with the operating manual

	M2-507	M2-510	M3-507	M3-510
	Y2			
HIT-360D			154	
HIT-400			174	
HIT-400L			174	
SIRIUS-UL+				364
SIRIUS-UM			274	264
SIRIUS-UX				
SIRIUS-UZ				364
VESTA 500T			174	
VESTA 850B				364
VESTA 610D		204	214	204
VESTA 660	189	179	189	179
VESTA-1000			300	290
VESTA-1050B				364
VESTA-1300				

### X-mounting

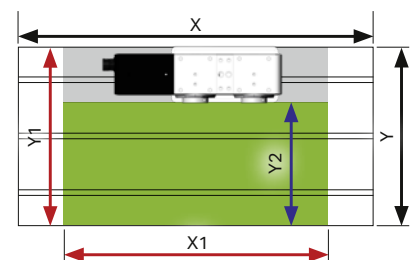

Rotary table installation with pL clamping claws in accordance with the operating manual







Very good accessibility, even with short tools

More space for workpieces and fixtures

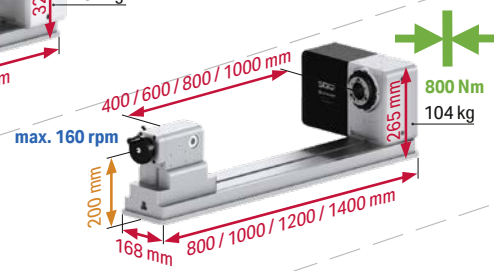
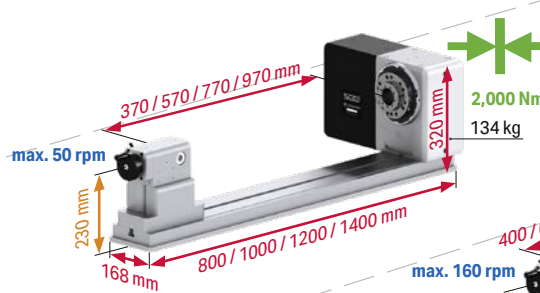
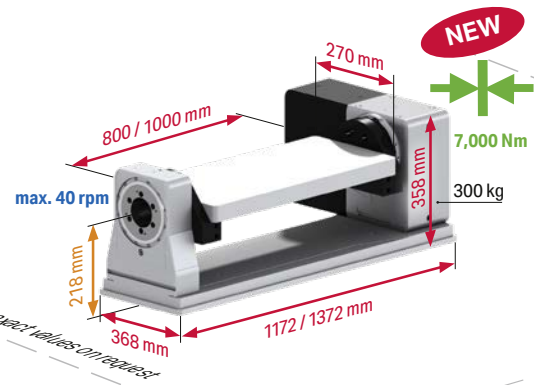
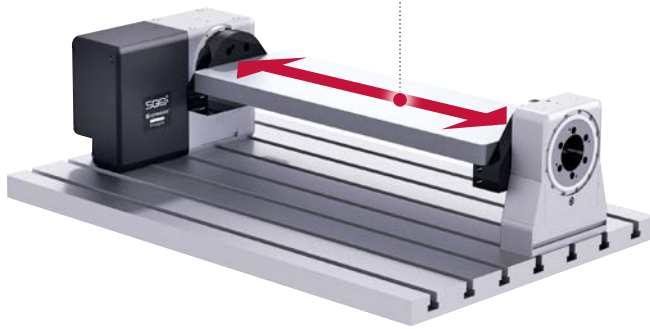

530

520

51x

50x

SIZE

### News in brief

1. High speed up to 210 rpm
2. Feed torque up to 850 Nm (tentative)
3. Steel base plates with hole pattern (suitable for slot spacing of 100 and 125 mm)
4. Cycle time 90° as fast as 0.21 sec.

 Weight data represent the standard load; higher weights possible, but require modification of rotational speed, acceleration and jerk limitation.

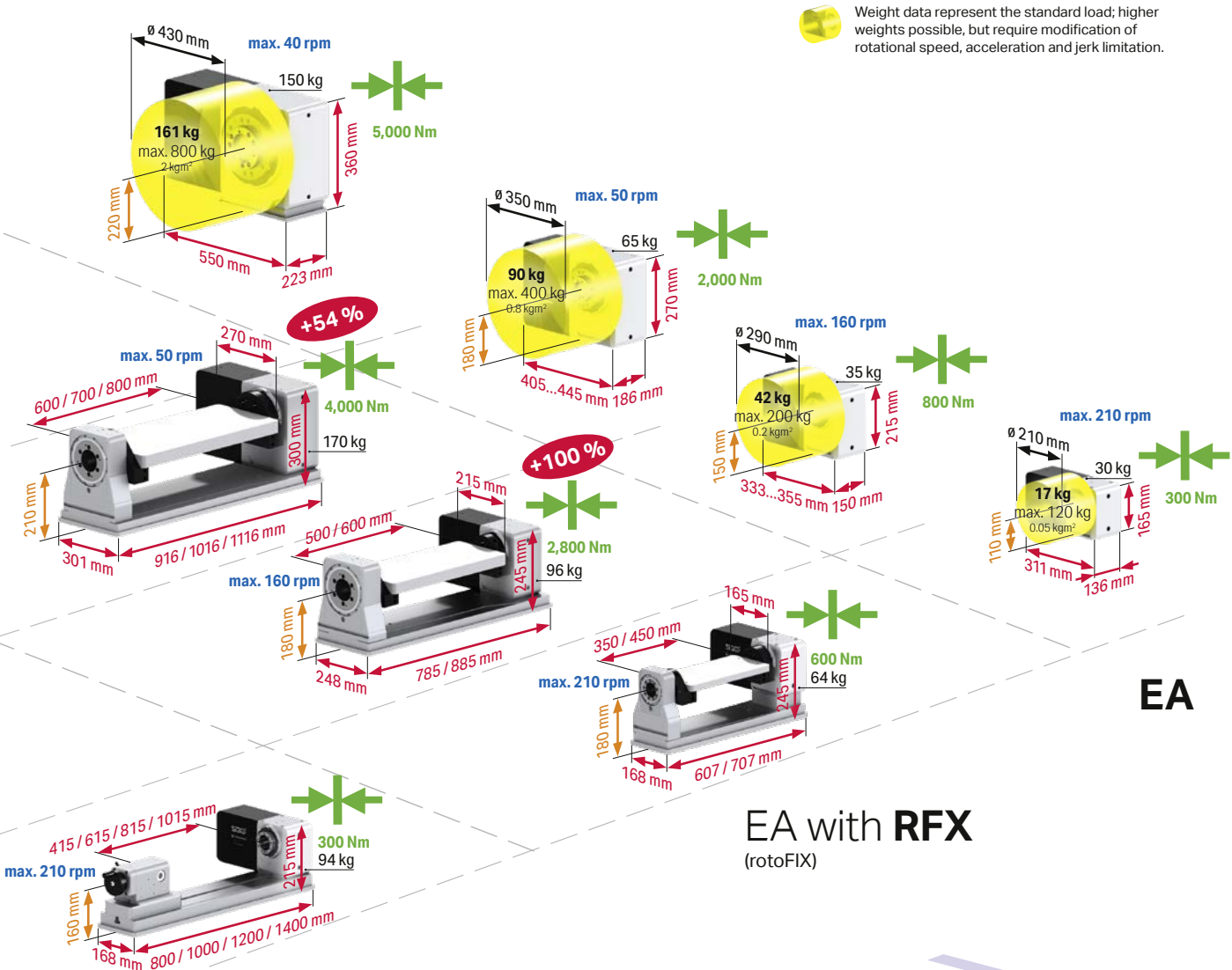

EA

EA with **RFX**  
(rotoFIX)

EA with **LFX**  
(longFLEX)

MODEL

- 50x 507 (standard) or 508 (high speed)
- 51x 510 (standard) or 511 (high speed)
- EA single-axis, single-spindle CNC rotary table
- rotoFIX modular clamping yoke system
- longFLEX modular shaft clamping system

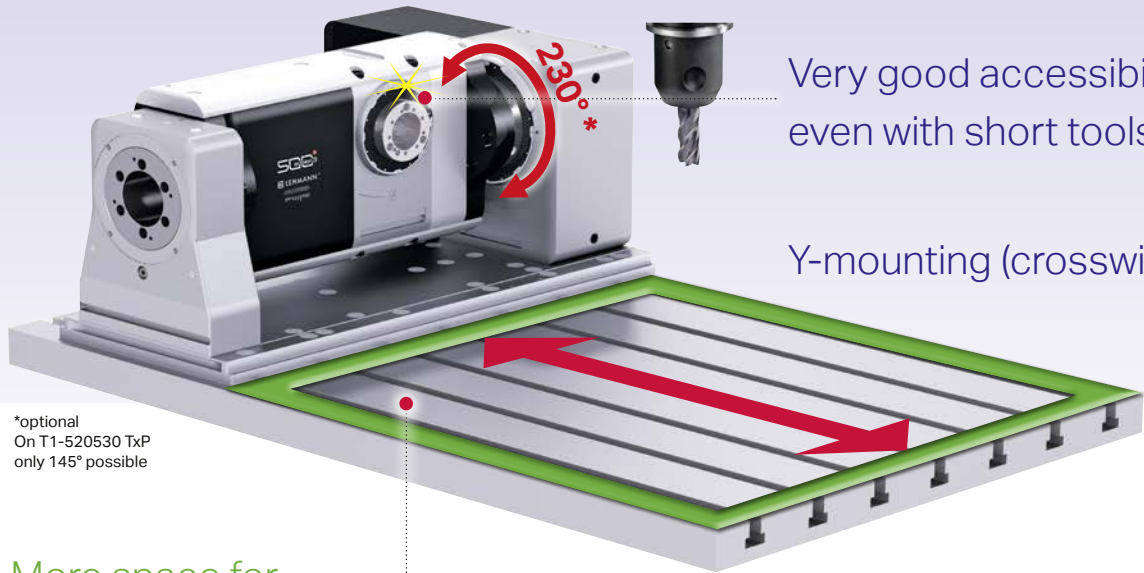

Very good accessibility, even with short tools

Y-mounting (crosswise)

\*optional  
On T1-520530 TxP  
only 145° possible

More space for workpiece and fixtures

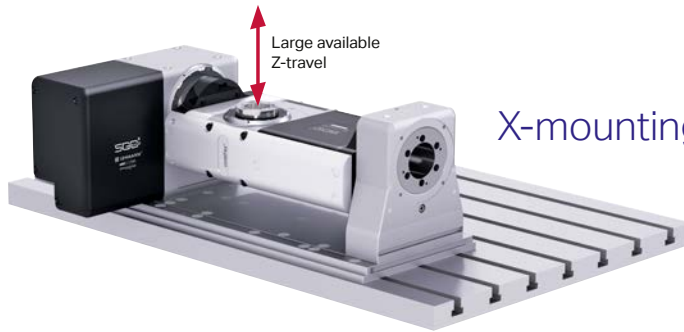

X-mounting (lengthwise)

**T1**

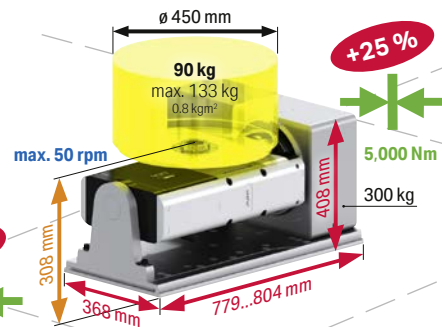

**T1**

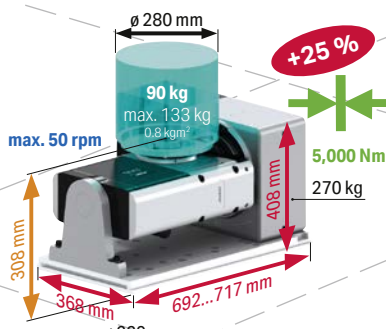

**T1**

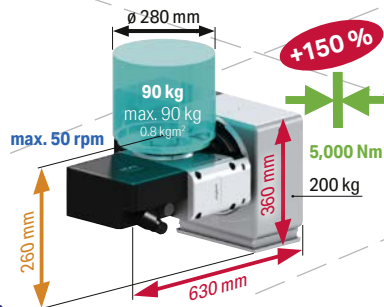

**TF**

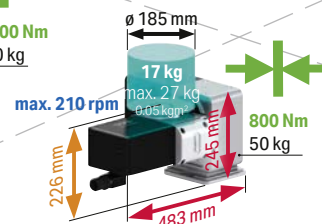
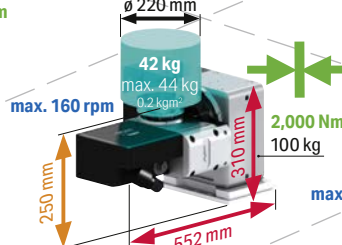
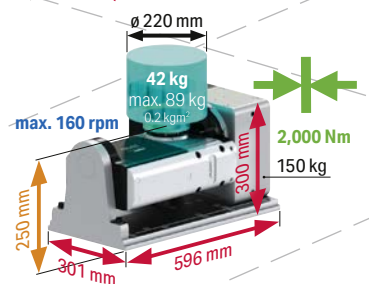

**TIPc**  
(compact)

520530 3  
51X520 2  
50X510 1  
**SIZE**

### News in brief

1. Up to 150% higher clamping torque in tilting axis
2. Fewer variant – more solution
3. Larger workpiece  $\varnothing$  possible
4. Spatially optimized arrangement of the dividing axis

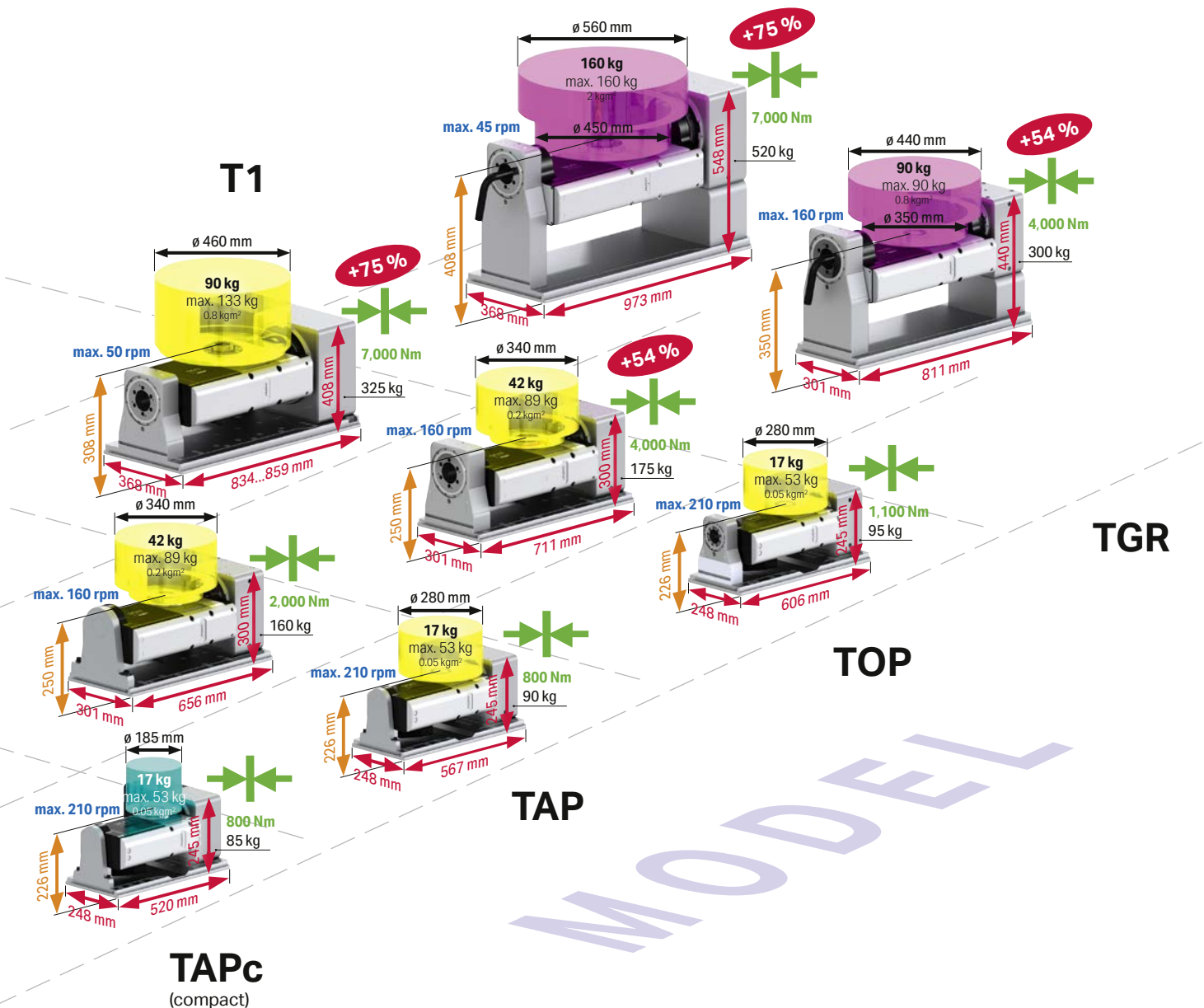

Weight data represent the standard load; higher weights possible, but require modification of rotational speed, acceleration and jerk limitation.

50x510	508510 (standard) or 508510 (high speed)
51x520	510520 (standard) or 511520 (high speed)
TIPc	Two-axis rotary table, no counter bearing, compact
TAPc	Two-axis rotary table, with supporting bearing, compact
TAP	Two-axis rotary table, with supporting bearing
TOP	Two-axis rotary table, with clamped counter bearing
TGR	Two-axis rotary table, with clamped counter bearing, specifically for grinding applications



More space for workpiece and fixtures



M2

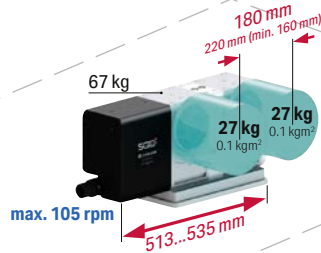

M3

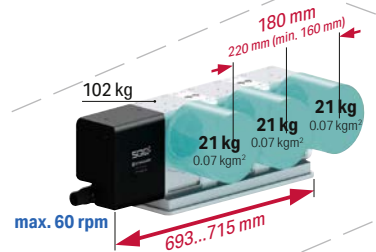

51x

50x

SIZE



### News in brief

1. Up to **54 %** higher clamping torque in tilting axis
2. Fewer variant – more solution
3. Spindle distance min. **130 mm**
4. Spatially optimized arrangement of the dividing axis

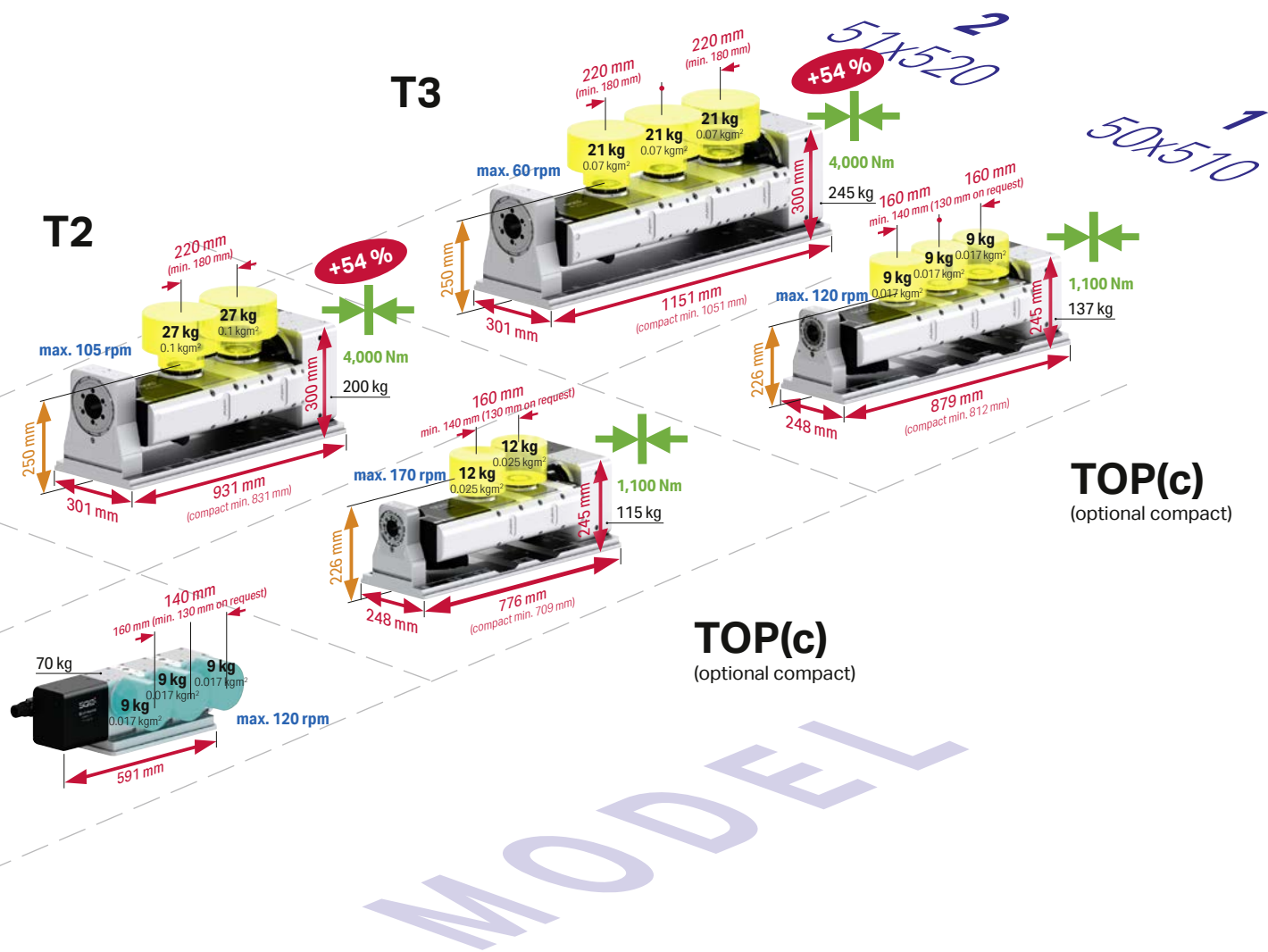

Weight data represent the standard load; higher weights possible, but require modification of rotational speed, acceleration and jerk limitation.

- 50x 507 (standard) or 508 (high speed)
- 51x 510 (standard) or 511 (high speed)
- M2 Single-axis, multi-spindle rotary table, 2-position
- M3 Single-axis, multi-spindle rotary table, 3-position
- T2 Two-axis multi-spindle rotary table, 2-position
- T3 Two-axis multi-spindle rotary table, 3-position

Extremely wide assortment for workpiece clamping.  
Standardized interface in front and rear: maximum universality

## Spindle accessories in rear

- + Rotary unions **up to 250 bar**
- + Clamping cylinder **23 kN at 120 bar**
- + Angular position measuring systems **as precise as  $\pm 1$  arcsec**



## Spindle accessories in front



## Tailstock and counter bearing



## ripas zero point clamping system



EA-507 with ripas auto and ripas adapter

## CAPTO clamping (on request)



EA-507 with CAPTO retrofit kit

Present in over 20 countries: from sales consultation to the final service



**Services from A to Z**

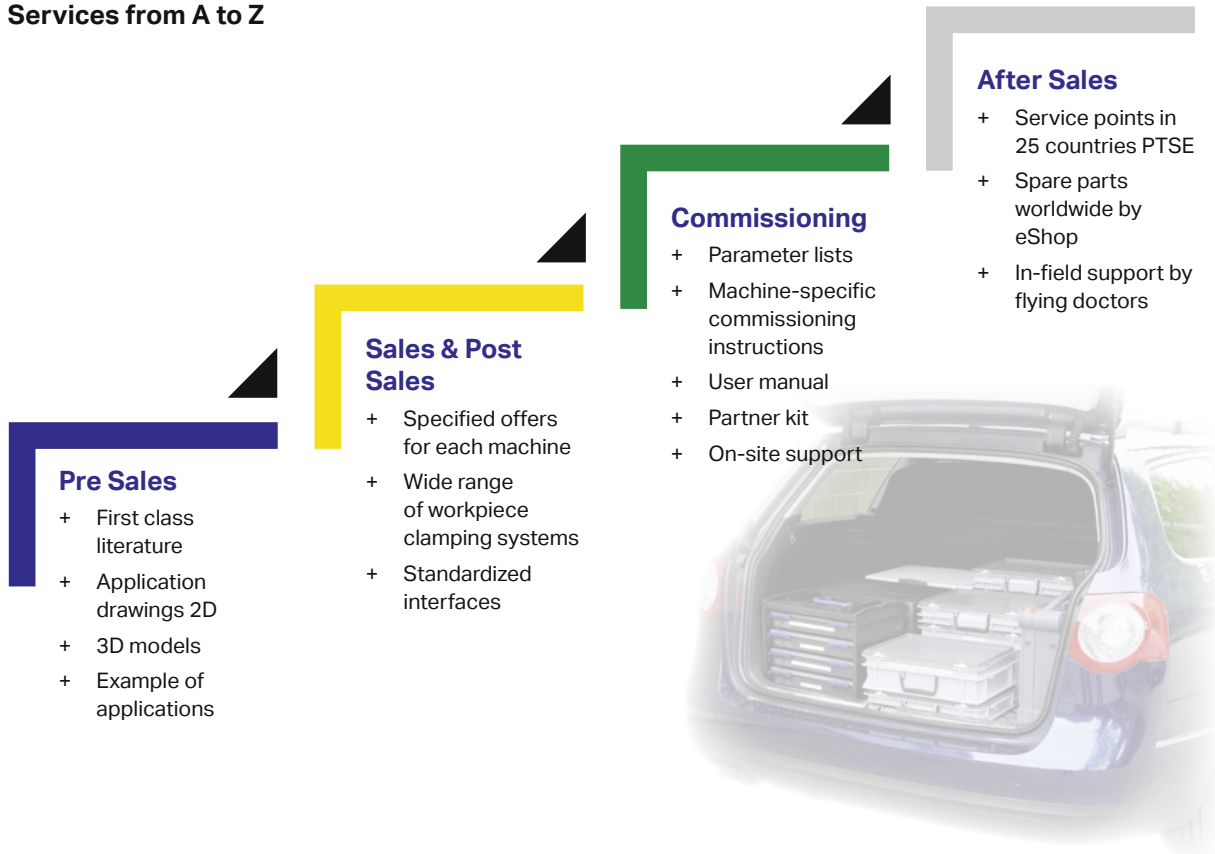

**Increase productivity – Extend lifecycle**

Comprehensive and professional services throughout the product life cycle – maximum availability with consistent quality and high productivity.

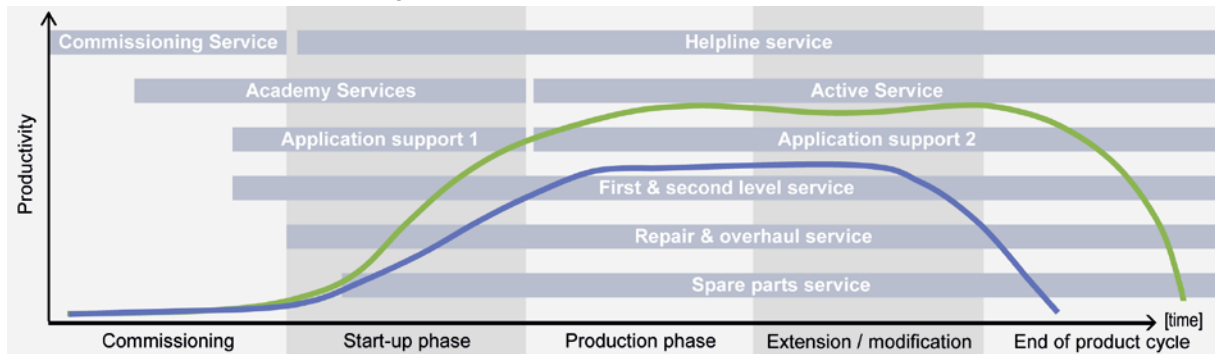

— Productivity with LifeCycle service products from pL LEHMANN  
 — Productivity without service support

For more information please see [www.lehmann-rotary-tables.com](http://www.lehmann-rotary-tables.com).



ROTARY TABLES · PRECISION TECHNOLOGY · SOFTWARE

#### Headquarters

PETER LEHMANN AG  
CH-3552 Bârau  
Phone +41 (0)34 409 66 66  
Fax +41 (0)34 409 66 00  
pls@plehmann.com  
www.lehmann-rotary-tables.com

#### Representatives / Agencies

##### Europe

- Austria
- Benelux
- Czech Republic (vacant)
- Finland
- France
- Germany
- Hungary (vacant)
- Italy
- Norway
- Poland
- Portugal
- Russia
- Slovenia
- Spain
- Sweden
- Turkey
- UK

##### America

- Brazil
- Canada
- Mexico
- USA

##### Asia

- China
- India
- Japan
- Malaysia
- Singapore
- South Korea
- Taiwan
- Thailand
- Vietnam

##### Africa

- South Africa

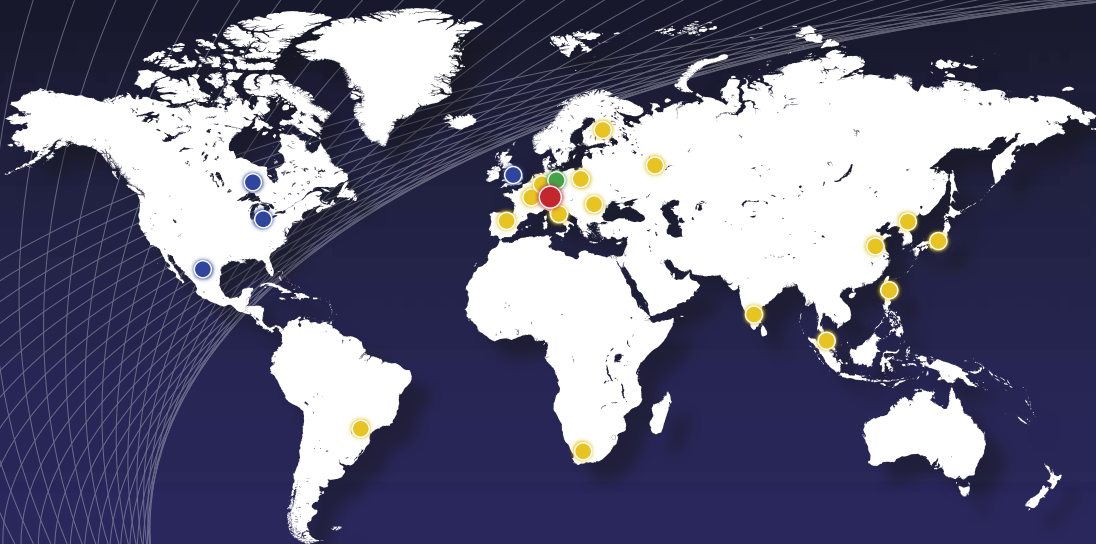

● Headquarters    ● direct sales partner    ● pL Solutions® partner    ● value added reseller & partner

More information (address, telephone number...) at [www.lehmann-rotary-tables.com](http://www.lehmann-rotary-tables.com)