



# Selection Guide for CNC Rotary Tables ...



Bluetooth®

pl

**HAAS**

10/2018 | EN



... for CM-, DM-, (S)MINIMILL-, TM-,  
VF- and VM-series

CNC rotary tables for economical manufacturing:  
pL LEHMANN has suitable and rational solutions for  
nearly every industry

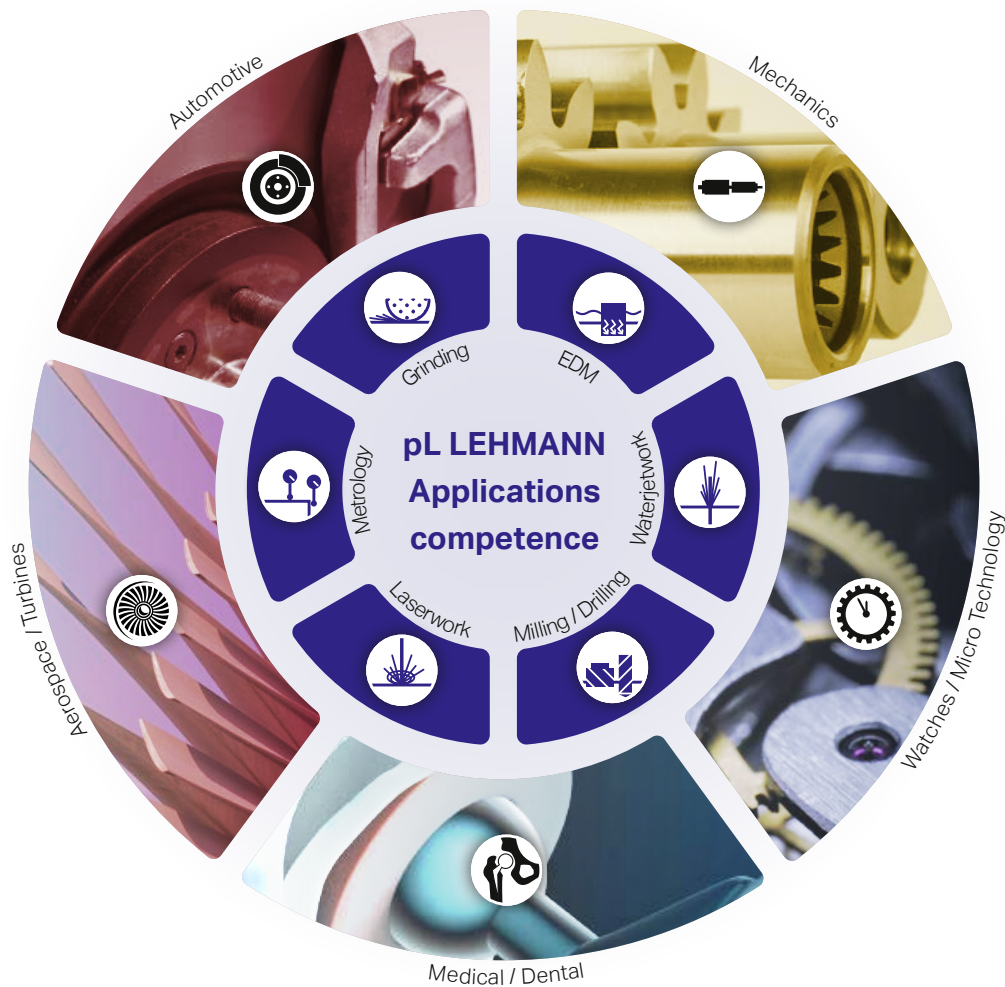

pL rotary tables in use: on over **40** different machine brands  
and over **160** different machine models.

pL competence: Integration in **all known** CNC control systems  
(Fanuc, Siemens, Heidenhain, Haas, Winmax, Mitsubishi, Brother,  
Mazatrol, Okuma ...), for new machines as well as for retrofits

Professional products from professional partners:  
 HAAS and pL LEHMANN provide  
 first-class service to common customers

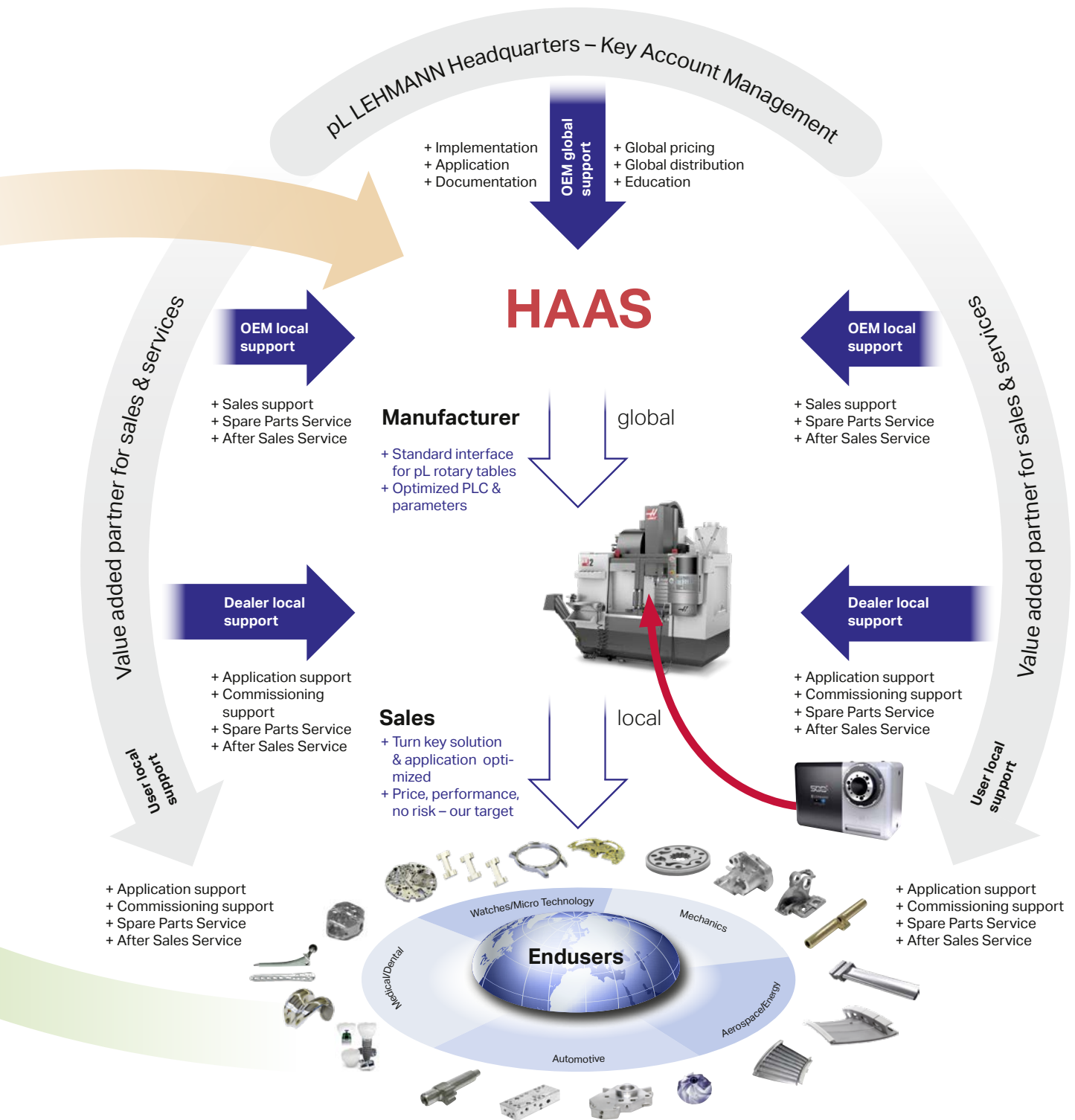

**NEW**  
up to +30 %

Up to 210 rpm  
up to 0.21 sec / 90°

**High speed**

Extended travel in  
Z- and X-direction

**More space**

High spindle load,  
heavy-duty bearing

**Heavy duty**

## E-Series



**Rotary tables suitable for simultaneous operation!**

### Save energy

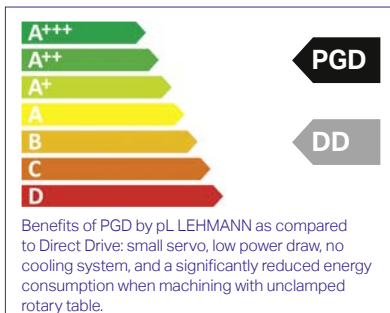

**Energy label at the left**  
An intuitive rating as consumption greatly depends on usage, and without any liability assumed, following the directives on energy labelling

**See main catalog for more features**

**NEW**  
up to +30 %

**High torque**

Feed torque up to  
**850 Nm** (provisional)

**Adaptability**

Multifunctional  
spindle HSK

**Precision**

On the workpiece, as  
precise as **2 µm / 100 mm**

**NEW**  
up to +150%

Pneum. clamping  
up to 7,000 Nm

**High clamp**

Large parts  
up to  $\varnothing$  500

**Big size**

PGD backlash-free  
long-life gear unit

**No backlash**



## T-Series



**All base plates  
made of steel**

**NEW**

with integrated hole pattern for  
slot spacing of 100 and 125 mm,  
integrated alignment system  
**lineFIX** for lengthwise or cross-  
wise clamping.

## M-Series



**Connectivity**

Wireless monitoring,  
for operation & service

**No adjust**

Load change without  
parameter adjustment

**Less cost**

No cooling system,  
no hydraulics



CM-1



DT-2



MINIMILL

## A word from HAAS:

**«Haas Automation is the largest machine tool builder in the western world**

Haas Automation produce top-quality products at affordable prices. By relying on volume sales rather than per-unit profits to build the company, Haas Automation delivers more standard features, high-tech innovations, and rock-solid engineering than perhaps any other CNC manufacturer in the world – and at better prices!»



TM-1



VF-2



VM-2

The right machine/rotary table combination for economical production: this Selection Guide helps you make the right selection

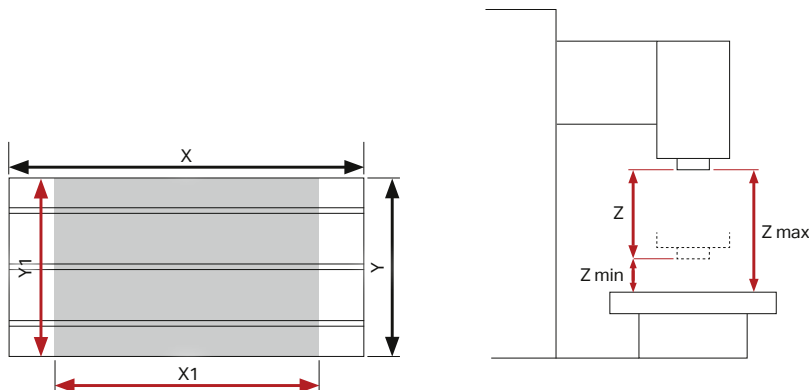

	Table diameter [mm]		Permissible overhang *	Traverse stroke [mm]					Table load ** max [kg]
	X	Y		X1	Y1	Z	Zmin	Zmax	
CM-1	508	254	40%	305	254	305	83	388	68
DM(DT)-1	660	380	10%	508	406	394	140	534	113
DM(DT)-2	860	380	10%	711	406	394	140	534	113
(S)MINIMILL (EDU)	910	730	10%	406	305	254	102	356	227
(S)MINIMILL2	1'020	360	10%	508	406	356	102	458	227
TM-1(P)	1'210	270	10%	762	305	406	102	508	454
TM-2(P)	1'470	270	10%	1'016	406	406	102	508	454
TM-3(P)	1'470	370	10%	1'016	508	406	102	508	454
VF-1	660	360	10%	508	406	508	102	610	1'361
VF-1YT	660	460	10%	508	508	508	102	610	1'361
VF-2(SS)	910	360	10%	762	406	508	102	610	1'361
VF-2(SS)YT	910	460	10%	762	508	508	102	610	1'361
VF-3(SS)	1'220	460	10%	1'016	508	635	102	737	1'588
VF-3(SS)YT	1'370	640	10%	1'016	660	635	114	749	1'588
VF-4(SS)	1'320	460	10%	1'270	508	635	102	737	1'588
VF-5/(SS)(40)(50)	1'320	580	10%	1'270	660	635	178	813	1'814
VF-5/40(50)XT	1'570	580	10%	1'524	660	635	201	836	1'814
VF-6/(SS)(40)(50)	1'630	710	10%	1'626	813	762	102	864	1'814
VM-2	910	460	10%	762	508	508	102	610	1'361
VM-3	1'370	640	10%	1'016	660	635	102	737	1'814
VM-6	1'630	710	10%	1'626	813	762	102	864	1'814

\* The recommended rotary tables can overhang the machine table by so many % (e.g. 10 % means: the rotary table length can be greater than dimension Y or X by max. 10 % of the machine width Y with Y-clamping or 10 % of the table length X with X-clamping.)

\*\* The recommended rotary tables do not exceed 50 % of the allowed table load.

### Table explanation for pp. 8–11

	EA-507 X2	EA-510 X2	EA-520 X2	EA-530 X2
CM-1	240			

Wherever values are listed, the combination is recommended. Empty cells mean that a combination is not possible, because the rotary table is too large, or is not recommended, because the rotary table is disproportionately small or heavier than 50% of the table load.

For further details about the rotary tables, see p. 12 and higher or refer to the main catalog



	EA-507 X2	EA-510 X2	EA-520 X2	EA-530 X2
CM-1	240			
DM(DT)-1	417	401		
DM(DT)-2	619	603		
(S)MINIMILL (EDU)			449	
(S)MINIMILL2	597	581		
TM-1(P)				
TM-2(P)				
TM-3(P)	1'076	1'060	1'034	
VF-1	417	401		
VF-1YT	417	401	375	
VF-2(SS)	669	653		
VF-2(SS)YT	669	653	627	
VF-3(SS)	951	935	909	
VF-3(SS)YT		1'010	984	955
VF-4(SS)	1'128	1'112	1'086	
VF-5/(SS)(40)(50)	1'128	1'112	1'086	1'057
VF-5/40(50)XT	1'380	1'364	1'338	1'309
VF-6/(SS)(40)(50)			1'419	1'390
VM-2	669	653	627	
VM-3		1'010	984	955
VM-6			1'419	1'390

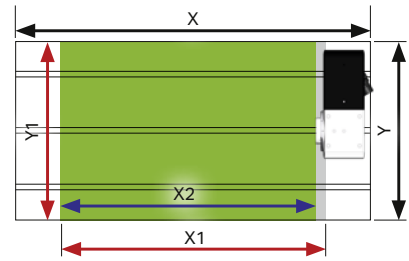

Rotary table installation with pL clamping claws in accordance with the operating manual

## Clamping yokes for EA-type rotary tables

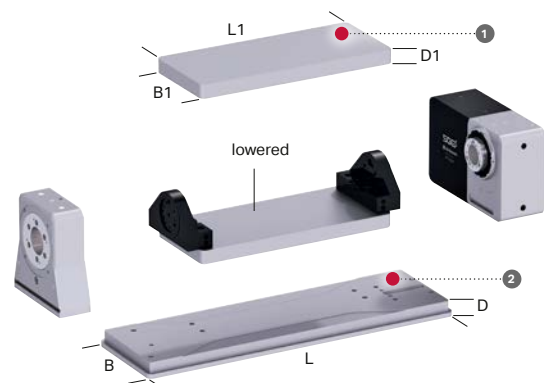

		EA-507	EA-510	EA-520	EA-530				
1 Clamping yokes	Sph	190	180	210	218				
	Length L1	350 450	500 600	600 700 800	800 1000				
	Width B1	165	215	270	270				
	Thickness D1	20	35	40	40				
2 Base plates	Length L	622 722	785 885	916 1016 1116	1172 1372				
	Width B	168	248	301	368				
	Thickness D	30	30	30	38				
Weights / moments of inertia (without rotary table, without counter bearing)	Weight (Al)	10	12	23	28	40	45	52	on request
	Weight (steel)	29	34	66	80	117	130	152	
	Mom. inert. (Al)	0.02	0.02	0.06	0.07	0.16	0.17	0.21	
	Mom. inert. (steel)	0.04	0.05	0.17	0.21	0.46	0.50	0.60	



## Explanations for pp. 8 to 11

The recommendations are for information purposes only. We recommend that you verify the effective dimensions prior to ordering. Modifications on the machine can lead to collisions and affect the dimensions X2 and Y2.



	M2-507	M2-510	M3-507	M3-510
	X2			
CM-1				
DM(DT)-1				
DM(DT)-2				
(S)MINIMILL (EDU)	432	422	432	422
(S)MINIMILL2				
TM-1(P)				
TM-2(P)				
TM-3(P)				
VF-1				
VF-1YT	358			
VF-2(SS)				
VF-2(SS)YT	610			
VF-3(SS)				
VF-3(SS)YT	967	957	967	957
VF-4(SS)	1'069			
VF-5/(SS)(40)(50)	1'069	1'059	1'069	
VF-5/40(50)XT	1'321	1'311	1'321	
VF-6/(SS)(40)(50)	1'402	1'392	1'402	1'392
VM-2	610			
VM-3	967	957	967	957
VM-6	1'402	1'392	1'402	1'392

## Y-mounting

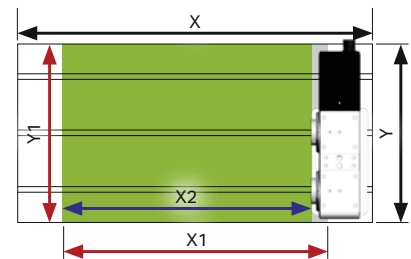

Rotary table installation with pL clamping claws in accordance with the operating manual

	M2-507	M2-510	M3-507	M3-510
	Y2			
CM-1				
DM(DT)-1	167			
DM(DT)-2	167			
(S)MINIMILL (EDU)				
(S)MINIMILL2		147	157	147
TM-1(P)				52
TM-2(P)				
TM-3(P)				
VF-1	157	147	157	147
VF-1YT		248	258	248
VF-2(SS)		147	157	147
VF-2(SS)YT		248	258	248
VF-3(SS)				248
VF-3(SS)YT				
VF-4(SS)				248
VF-5/(SS)(40)(50)				384
VF-5/40(50)XT				
VF-6/(SS)(40)(50)				
VM-2		248	258	248
VM-3				
VM-6				

## X-mounting

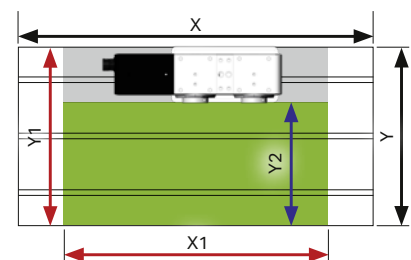

Rotary table installation with pL clamping claws in accordance with the operating manual

## Y-mounting

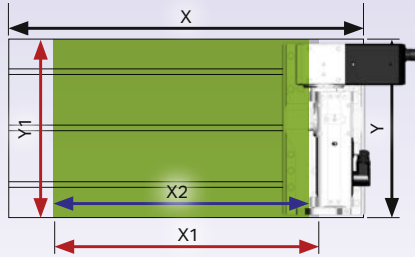

Rotary table installation using hole pattern in base plate



TIP1



TAP1



TOP1.2

**Important remark:** The tilting range of 180° (order no. SWB.5xx-180) can be used under usual reserve only, because the limit switches are also used as reference switches.

	TIP1c TF-507510 X2	TIP2c TF-510520 X2	TIP3c TF-520530 X2	TAP1c T1-507510 X2	TAP2c T1-510520 X2	TAP3c T1-520530 X2	TAP1 T1-507510 X2	TAP2 T1-510520 X2	TAP3 T1-520530 X2	TOP1 T1-507510 X2
CM-1										
DM(DT)-1										
DM(DT)-2										
(S)MINIMILL (EDU)	528	484		488			488			488
(S)MINIMILL2										
TM-1(P)										
TM-2(P)										
TM-3(P)										
VF-1										
VF-1YT	454									
VF-2(SS)										
VF-2(SS)YT	706									
VF-3(SS)	988									
VF-3(SS)YT	1'063	1'019	999	1'023	1'003	969	1'023	1'003		1'023
VF-4(SS)	1'165									
VF-5/(SS)(40)(50)	1'165	1'121	1'101	1'125	1'105		1'125			1'125
VF-5/40(50)XT	1'417	1'373	1'353	1'377	1'357		1'377			1'377
VF-6/(SS)(40)(50)	1'498	1'454	1'434	1'458	1'438	1'404	1'458	1'438	1'404	1'458
VM-2	706									
VM-3	1'063	1'019	999	1'023	1'003	969	1'023	1'003		1'023
VM-6	1'498	1'454	1'434	1'458	1'438	1'404	1'458	1'438	1'404	1'458

	TOP2 T1-510520 X2	TOP3 T1-520530 X2	TAP1c.2 T1-507510 X2	TAP2c.2 T1-510520 X2	TAP3c.2 T1-520530 X2	TAP1.2 T1-507510 X2	TAP2.2 T1-510520 X2	TAP3.2 T1-520530 X2	TOP1.2 T2-507510 X2	TOP2.2 T2-510520 X2	TOP3.2 T2-520530 X2
CM-1											
DM(DT)-1											
DM(DT)-2											
(S)MINIMILL (EDU)			488			488			488		
(S)MINIMILL2											
TM-1(P)											
TM-2(P)											
TM-3(P)											
VF-1											
VF-1YT											
VF-2(SS)											
VF-2(SS)YT											
VF-3(SS)											
VF-3(SS)YT			1'023								
VF-4(SS)											
VF-5/(SS)(40)(50)											
VF-5/40(50)XT											
VF-6/(SS)(40)(50)	1'438		1'458			1'458			1'458		
VM-2											
VM-3			1'023								
VM-6	1'438		1'458			1'458			1'458		

## X-mounting

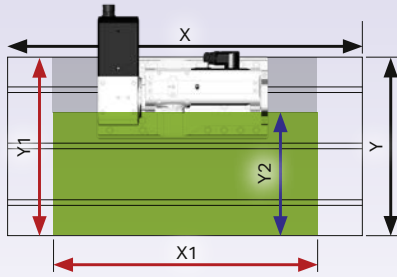

Rotary table installation using hole pattern in base plate



TIP1



TAP1



TOP1.2

**Important remark:** The tilting range of 180° (order no. SWB.5xx-180) can be used under usual reserve only, because the limit switches are also used as reference switches.

	TIP1c TF-507510 Y2	TIP2c TF-510520 Y2	TIP3c TF-520530 Y2	TAP1c T1-507510 Y2	TAP2c T1-510520 Y2	TAP3c T1-520530 Y2	TAP1 T1-507510 Y2	TAP2 T1-510520 Y2	TAP3 T1-520530 Y2	TOP1 T1-507510 Y2
CM-1										
DM(DT)-1	263									
DM(DT)-2	263									
(S)MINIMILL (EDU)										
(S)MINIMILL2		209		213			213			213
TM-1(P)			94					98		118
TM-2(P)										
TM-3(P)										
VF-1	253	209	189	213	193	159	213	193		213
VF-1YT		310	290	314	294	260	314	294		314
VF-2(SS)	253	209	189	213	193	159	213	193	159	213
VF-2(SS)YT		310	290	314	294	260	314	294	260	314
VF-3(SS)			290			260		294	260	
VF-3(SS)YT									426	
VF-4(SS)						260			260	
VF-5/(SS)(40)(50)						396			396	
VF-5/40(50)XT										
VF-6/(SS)(40)(50)										
VM-2		310	290	314	294	260	314	294	260	314
VM-3									426	
VM-6										

	TOP2 T1-510520 Y2	TOP3 T1-520530 Y2	TAP1c.2 T1-507510 Y2	TAP2c.2 T1-510520 Y2	TAP3c.2 T1-520530 Y2	TAP1.2 T1-507510 Y2	TAP2.2 T1-510520 Y2	TAP3.2 T1-520530 Y2	TOP1.2 T2-507510 Y2	TOP2.2 T2-510520 Y2	TOP3.2 T2-520530 Y2
CM-1											
DM(DT)-1											
DM(DT)-2											
(S)MINIMILL (EDU)											
(S)MINIMILL2			213			213			213		
TM-1(P)	98		118	98		118	98		118	98	
TM-2(P)				148			148		168	148	
TM-3(P)				249			249		269	249	
VF-1	193		213			213					
VF-1YT	294		314			314					
VF-2(SS)	193	159	213	193		213	193		213	193	
VF-2(SS)YT	294	260	314	294		314	294		314	294	
VF-3(SS)	294	260	314	294	260	314	294	260	314	294	260
VF-3(SS)YT	460	426		460	426	480	460	426	480	460	426
VF-4(SS)	294	260	314	294	260	314	294	260	314	294	260
VF-5/(SS)(40)(50)	430	396	450	430	396	450	430	396	450	430	396
VF-5/40(50)XT		396		430	396		430	396		430	396
VF-6/(SS)(40)(50)		538		572	538		572	538		572	538
VM-2	294	260	314	294		314	294		314	294	
VM-3	460	426		460	426	480	460	426	480	460	426
VM-6		538		572	538		572	538		572	538



Very good accessibility, even with short tools

More space for workpieces and fixtures

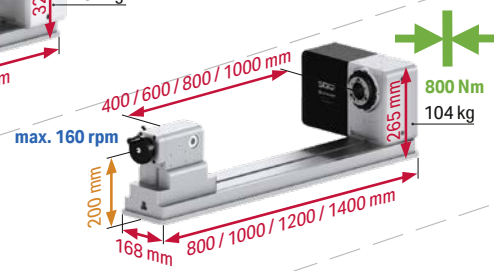
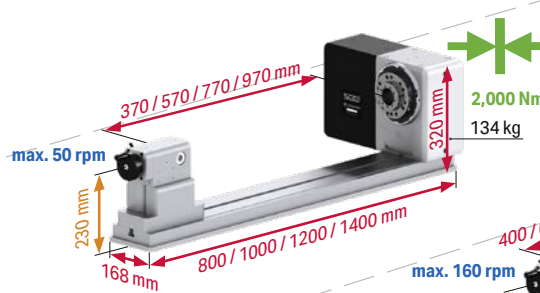
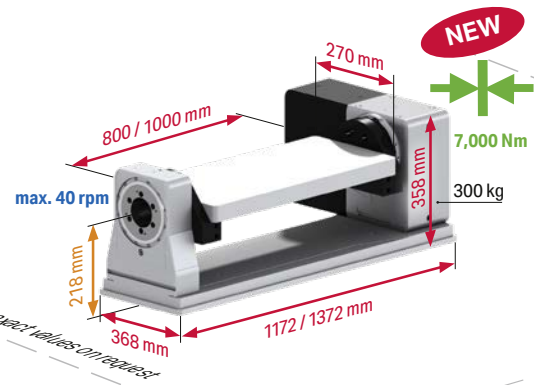
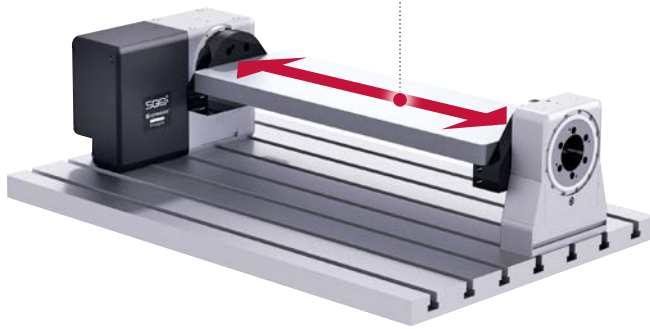

530

520

51x

50x

SIZE

### News in brief

1. High speed up to 210 rpm
2. Feed torque up to 850 Nm (tentative)
3. Steel base plates with hole pattern (suitable for slot spacing of 100 and 125 mm)
4. Cycle time 90° as fast as 0.21 sec.

 Weight data represent the standard load; higher weights possible, but require modification of rotational speed, acceleration and jerk limitation.

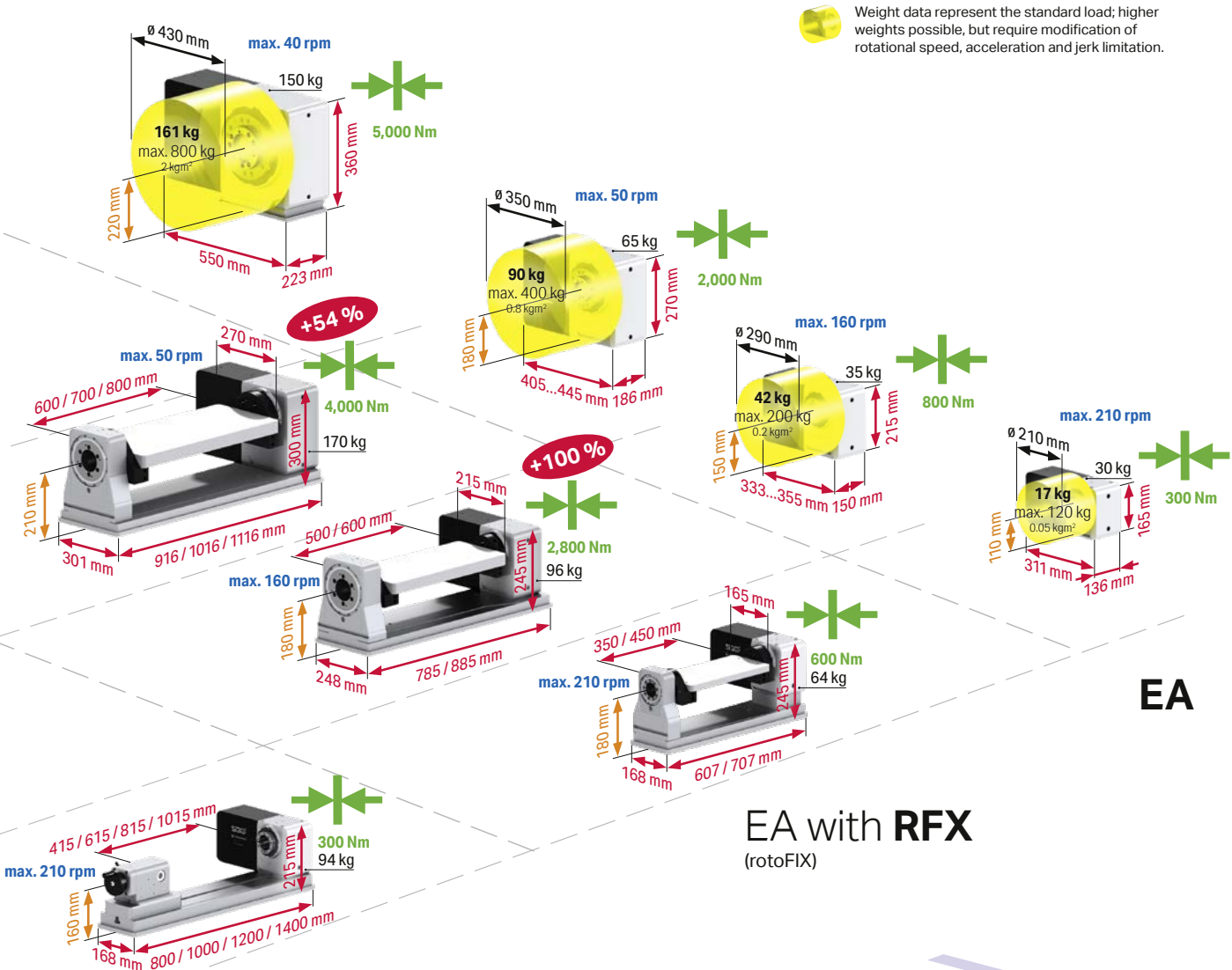

EA

EA with **RFX**  
(rotoFIX)

EA with **LFX**  
(longFLEX)

MODEL

50x	507 (standard) or 508 (high speed)
51x	510 (standard) or 511 (high speed)
EA	single-axis, single-spindle CNC rotary table
rotoFIX	modular clamping yoke system
longFLEX	modular shaft clamping system

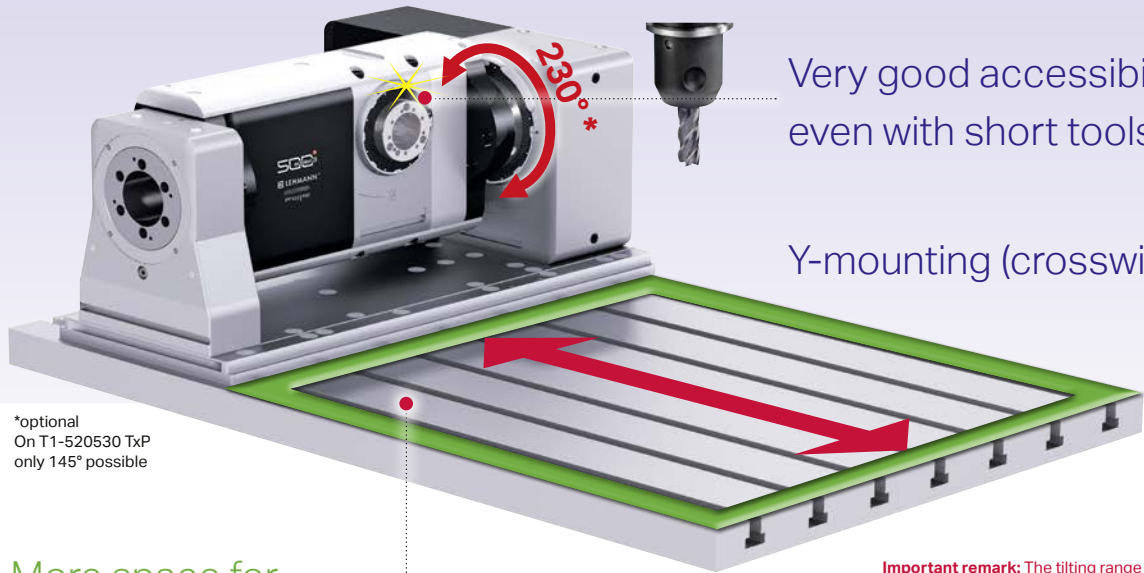

Very good accessibility, even with short tools

Y-mounting (crosswise)

\*optional  
On T1-520530 TxP  
only 145° possible

More space for workpiece and fixtures

**Important remark:** The tilting range of 180° (order no. SWB.5xx-180) can be used under usual reserve only, because the limit switches are also used as reference switches.

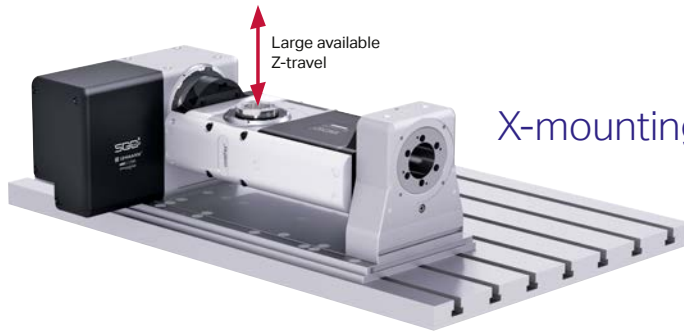

X-mounting (lengthwise)

T1

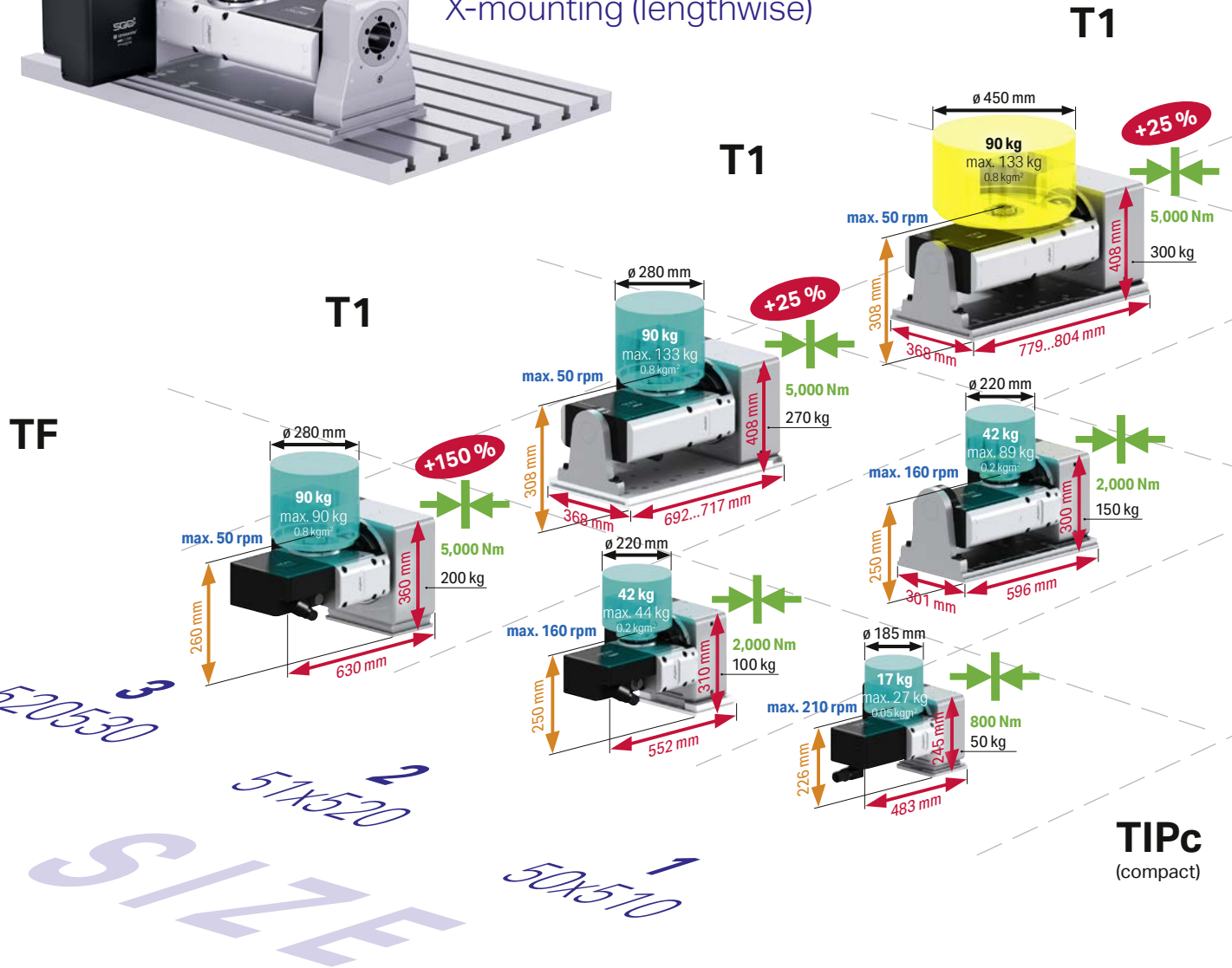

### News in brief

1. Up to 150% higher clamping torque in tilting axis
2. Fewer variant – more solution
3. Larger workpiece  $\varnothing$  possible
4. Spatially optimized arrangement of the dividing axis

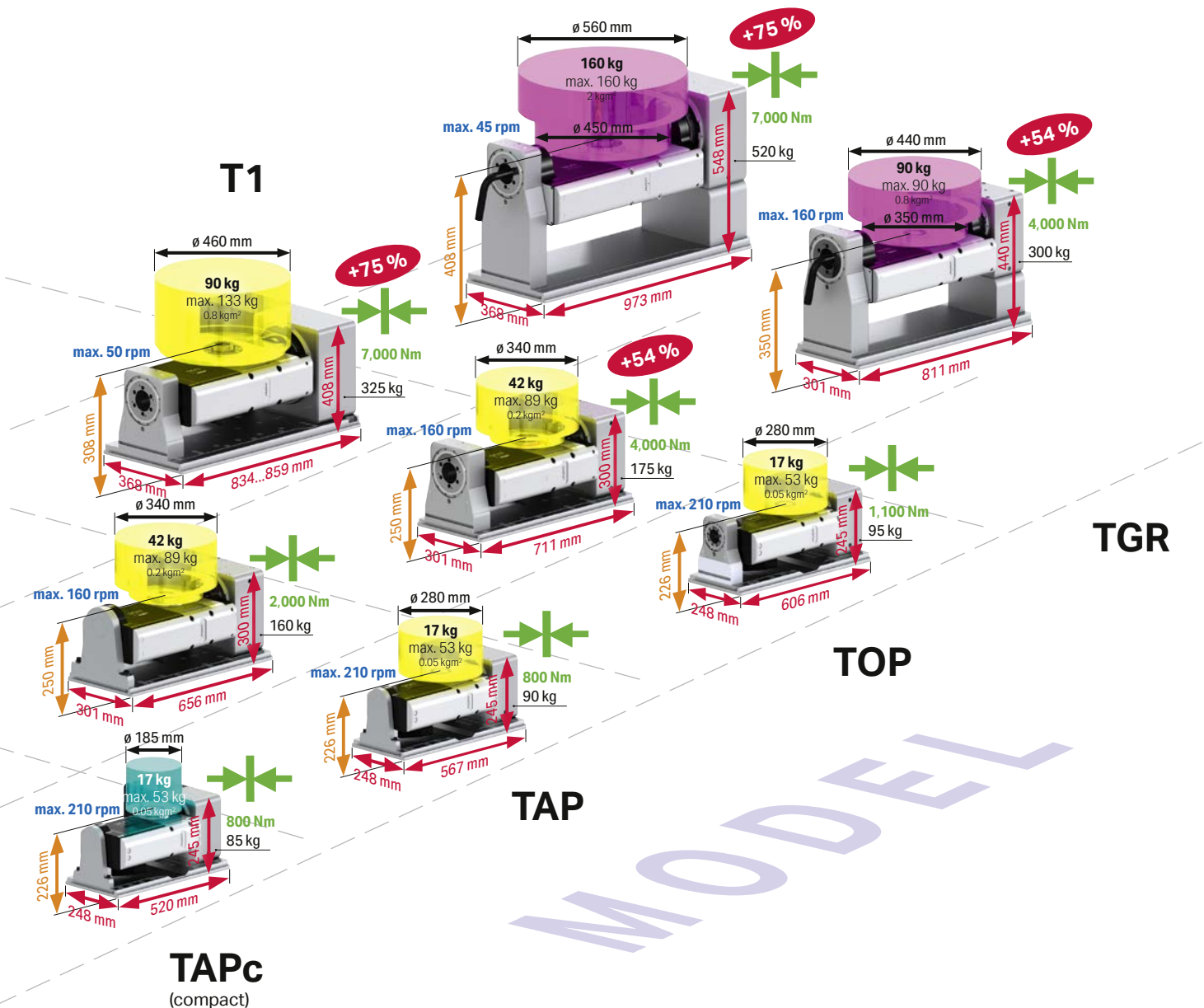

Weight data represent the standard load; higher weights possible, but require modification of rotational speed, acceleration and jerk limitation.

- 50x510 508510 (standard) or 508510 (high speed)
- 51x520 510520 (standard) or 511520 (high speed)
- TIPc Two-axis rotary table, no counter bearing, compact
- TAPc Two-axis rotary table, with supporting bearing, compact
- TAP Two-axis rotary table, with supporting bearing
- TOP Two-axis rotary table, with clamped counter bearing
- TGR Two-axis rotary table, with clamped counter bearing, specifically for grinding applications



More space for workpiece and fixtures



M2

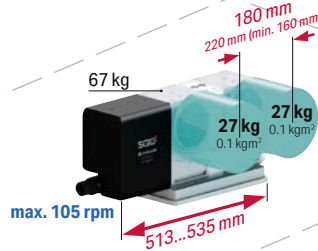

M3

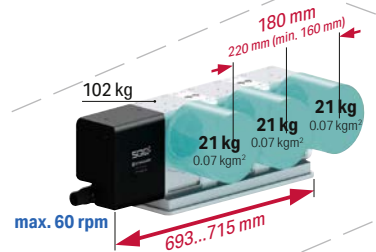

51x

50x

SIZE



### News in brief

1. Up to **54 %** higher clamping torque in tilting axis
2. Fewer variant – more solution
3. Spindle distance min. **130 mm**
4. Spatially optimized arrangement of the dividing axis

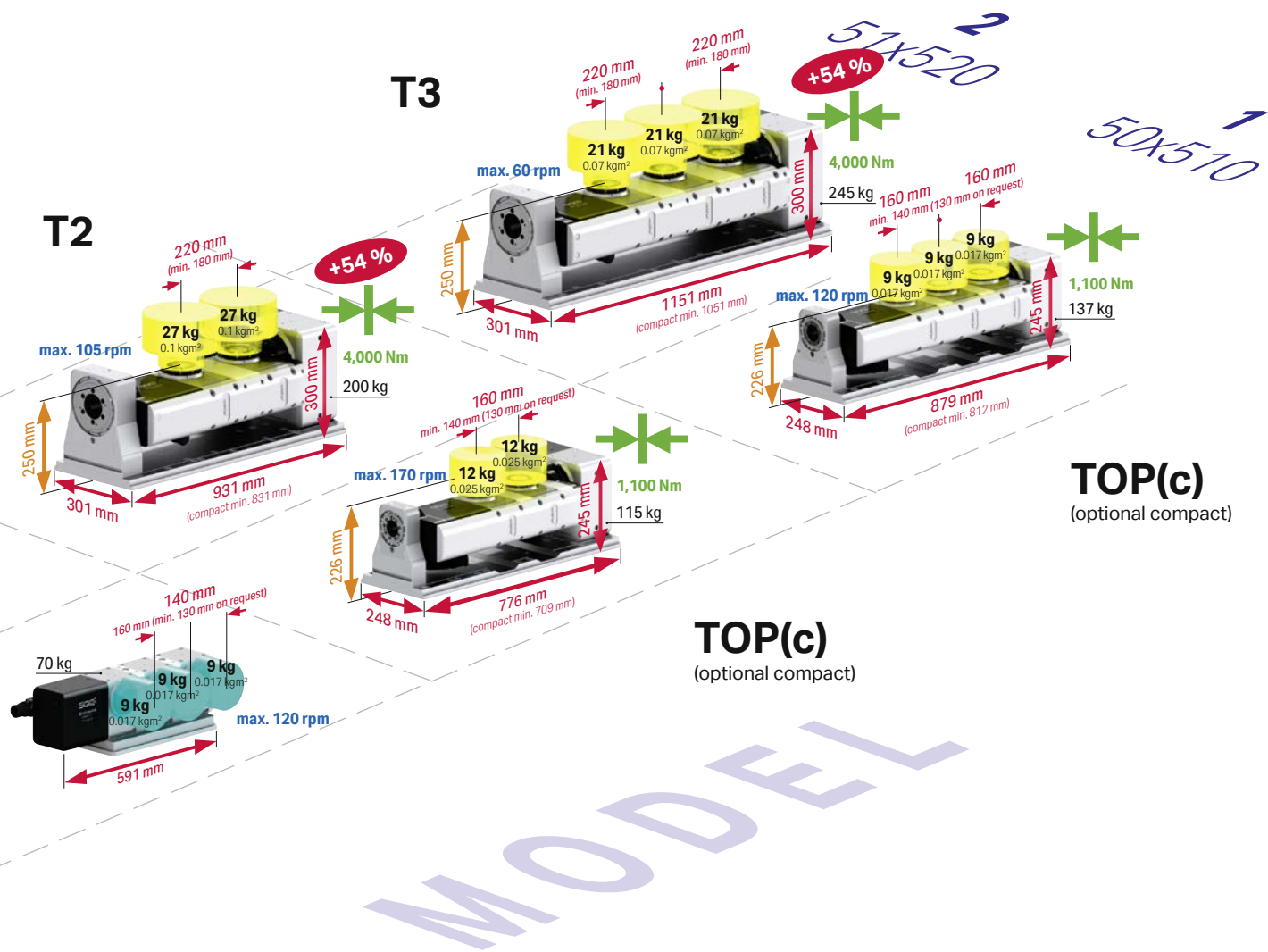

Weight data represent the standard load; higher weights possible, but require modification of rotational speed, acceleration and jerk limitation.

- 50x 507 (standard) or 508 (high speed)
- 51x 510 (standard) or 511 (high speed)
- M2 Single-axis, multi-spindle rotary table, 2-position
- M3 Single-axis, multi-spindle rotary table, 3-position
- T2 Two-axis multi-spindle rotary table, 2-position
- T3 Two-axis multi-spindle rotary table, 3-position

Extremely wide assortment for workpiece clamping.  
Standardized interface in front and rear: maximum universality

## Spindle accessories in rear

- + Rotary unions **up to 250 bar**
- + Clamping cylinder **23 kN at 120 bar**
- + Angular position measuring systems **as precise as  $\pm 1$  arcsec**



## Spindle accessories in front



## Tailstock and counter bearing



## ripas zero point clamping system



EA-507 with ripas auto and ripas adapter

## CAPTO clamping (on request)



EA-507 with CAPTO retrofit kit

Present in over 20 countries: from sales consultation to the final service



**Services from A to Z**

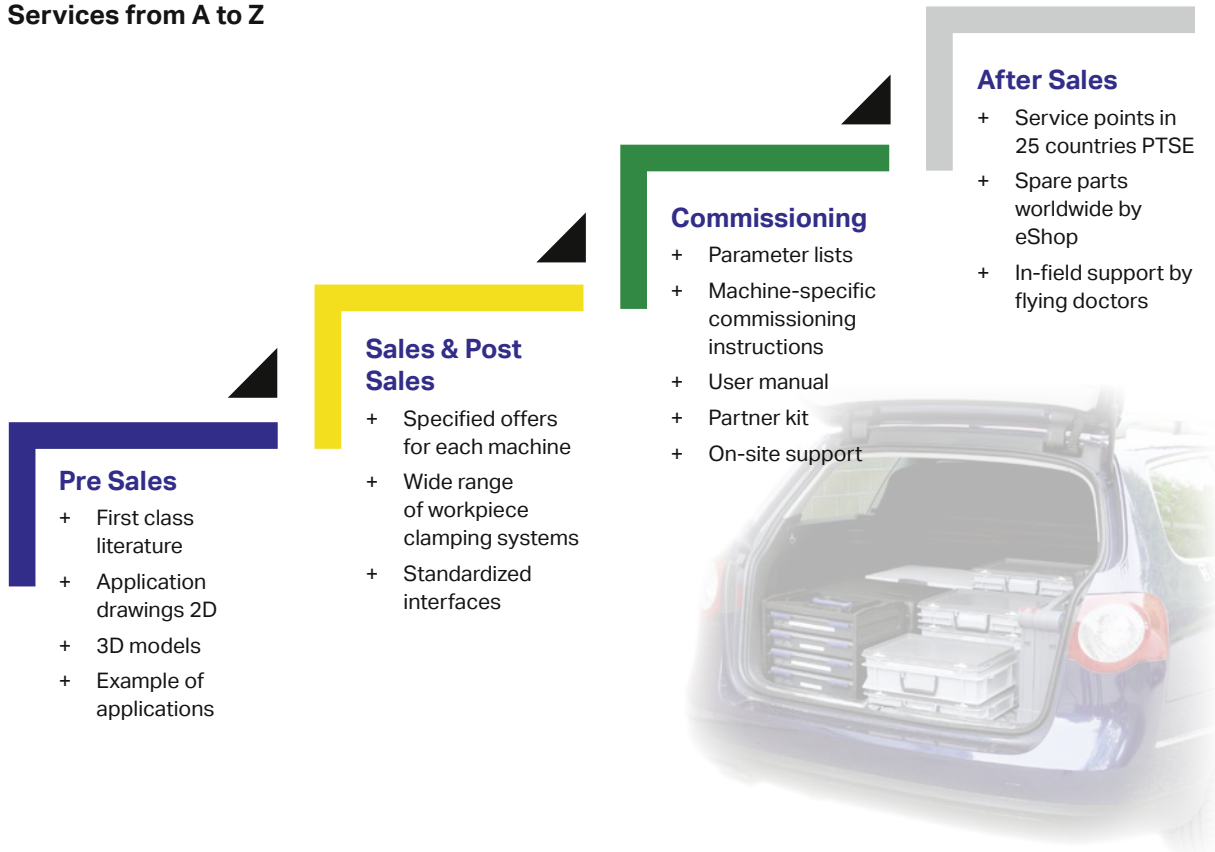

**Increase productivity – Extend lifecycle**

Comprehensive and professional services throughout the product life cycle – maximum availability with consistent quality and high productivity.

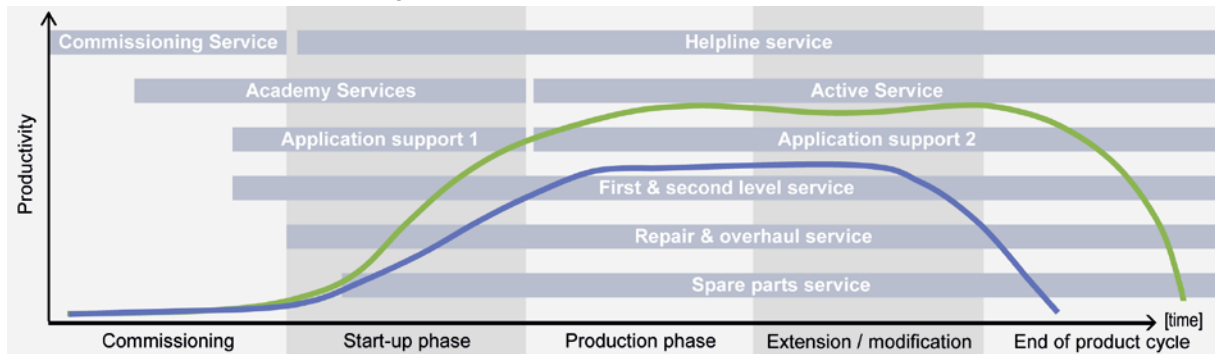

— Productivity with LifeCycle service products from pL LEHMANN  
 — Productivity without service support

For more information please see [www.lehmann-rotary-tables.com](http://www.lehmann-rotary-tables.com).



ROTARY TABLES · PRECISION TECHNOLOGY · SOFTWARE

#### Headquarters

PETER LEHMANN AG  
CH-3552 Bârau  
Phone +41 (0)34 409 66 66  
Fax +41 (0)34 409 66 00  
pls@plehmann.com  
www.lehmann-rotary-tables.com

#### Representatives / Agencies

##### Europe

- Austria
- Benelux
- Czech Republic (vacant)
- Finland
- France
- Germany
- Hungary (vacant)
- Italy
- Norway
- Poland
- Portugal
- Russia
- Slovenia
- Spain
- Sweden
- Turkey
- UK

##### America

- Brazil
- Canada
- Mexico
- USA

##### Asia

- China
- India
- Japan
- Malaysia
- Singapore
- South Korea
- Taiwan
- Thailand
- Vietnam

##### Africa

- South Africa

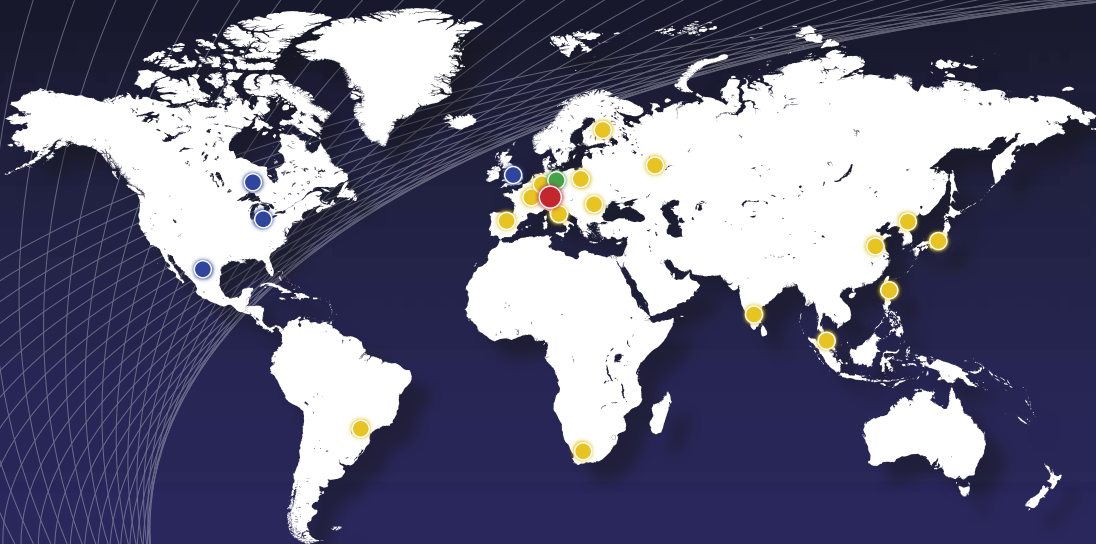

● Headquarters    ● direct sales partner    ● pL Solutions® partner    ● value added reseller & partner

More information (address, telephone number...) at [www.lehmann-rotary-tables.com](http://www.lehmann-rotary-tables.com)