



Selection Guide for CNC Rotary Tables ...



Bluetooth®

pl

brother

6/2019 | EN



... for SPEEDIO series

CNC rotary tables for economical manufacturing:
pL LEHMANN has suitable and rational solutions for
nearly every industry

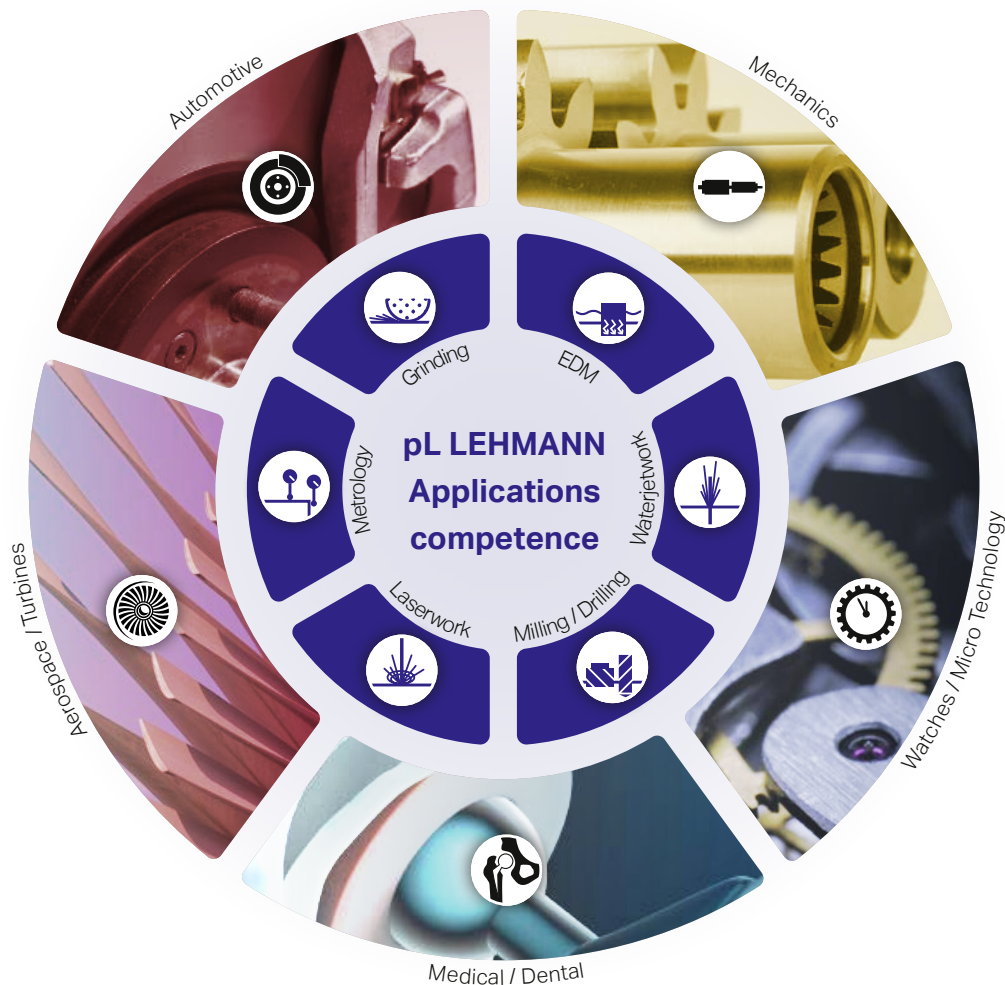

pL rotary tables in use: on over **40** different machine brands
and over **160** different machine models.

pL competence: Integration in **all known** CNC control systems
(Fanuc, Siemens, Heidenhain, Haas, Winmax, Mitsubishi, Brother,
Mazatrol, Okuma ...), for new machines as well as for retrofits

Professional products from professional partners:
 Brother and pL LEHMANN provide
 first-class service to common customers

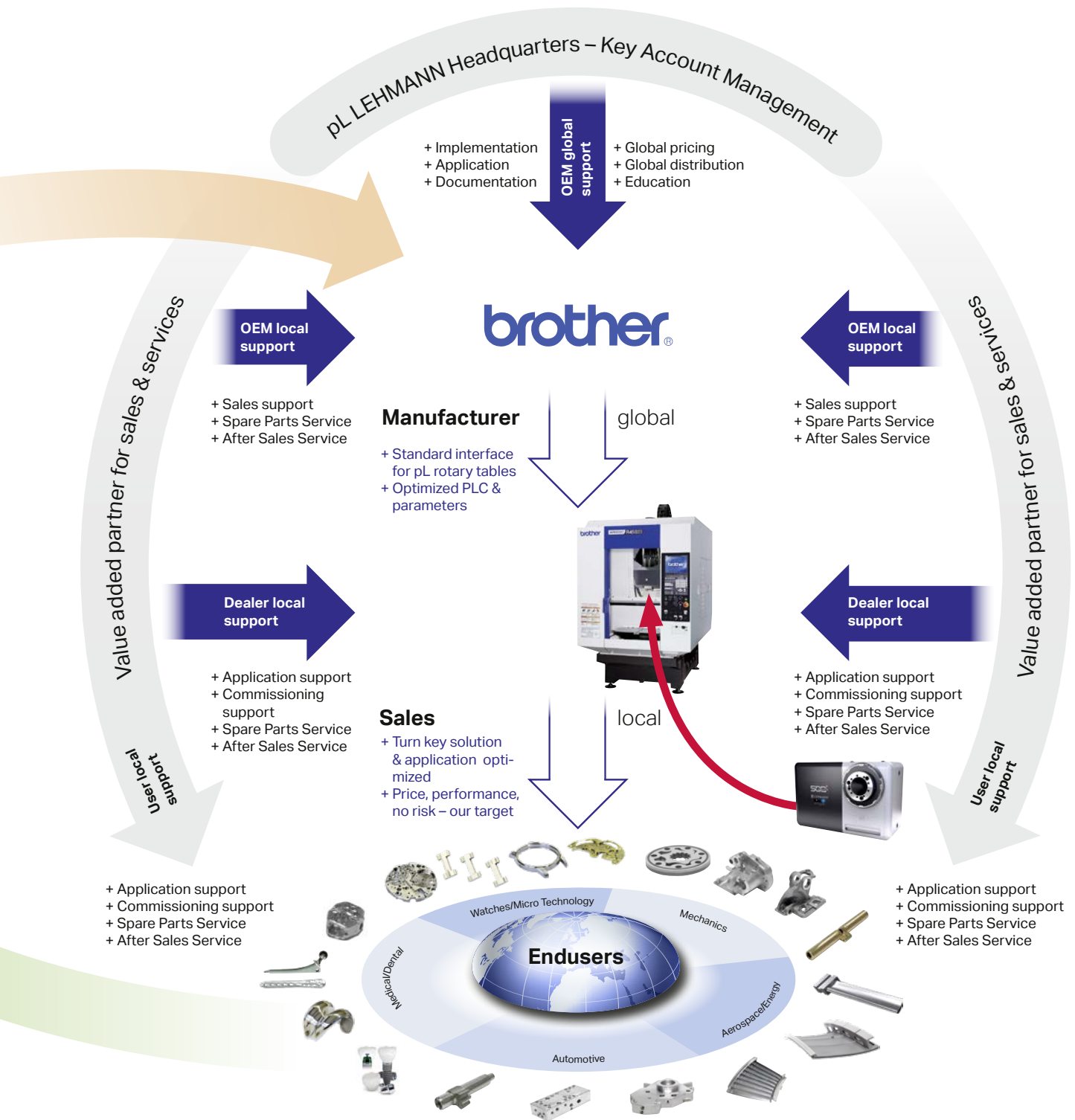

NEW
up to +30 %

Up to 210 rpm
up to 0.21 sec / 90°

Extended travel in
Z- and X-direction

High spindle load,
heavy-duty bearing

High speed

More space

Heavy duty

E-Series



Rotary tables suitable for simultaneous operation!

Save energy

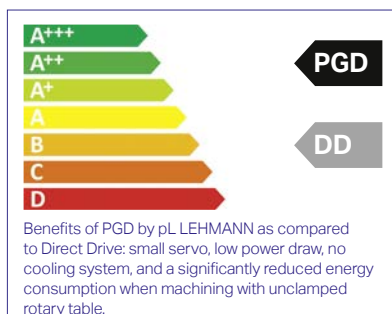

Energy label at the left
An intuitive rating as consumption greatly depends on usage, and without any liability assumed, following the directives on energy labelling

See main catalog for more features

NEW
up to +30 %

High torque

Feed torque up to
850 Nm (provisional)

Adaptability

Multifunctional
spindle HSK

Precision

On the workpiece, as
precise as 2 µm / 100 mm

NEW
up to +150%

Pneum. clamping
up to 7,000 Nm

High clamp

Large parts
up to \varnothing 500

Big size

PGD backlash-free
long-life gear unit

No backlash



T-Series



**All base plates
made of steel**

NEW

with integrated hole pattern for
slot spacing of 100 and 125 mm,
integrated alignment system
lineFIX for lengthwise or cross-
wise clamping.

M-Series



NEW

Connectivity

Wireless monitoring,
for operation & service

No adjust

Load change without
parameter adjustment

Less cost

No cooling system,
no hydraulics

Simple assembly by customers

Suitable for Quicktable: SPEEDIO R450X2, SPEEDIO R650X2
(no adaptation of machines required!)

Important information (applies to all machines): Per axis, 3 (divider) and 5 (swiveller / tilter) digital inputs as well as 1 digital output per axis are required so that the spindle clamping signals «clamped/released» can be queried properly.

EA and M rotary tables (4 axes)

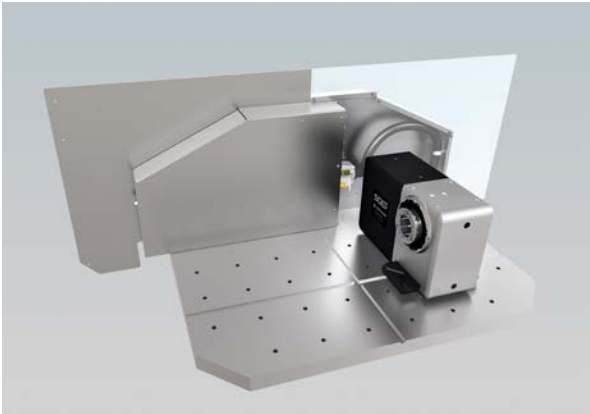

Front view

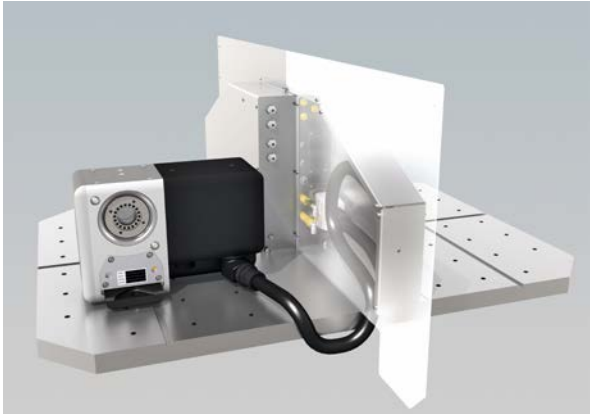

Rear view

T rotary tables (4/5 axes)

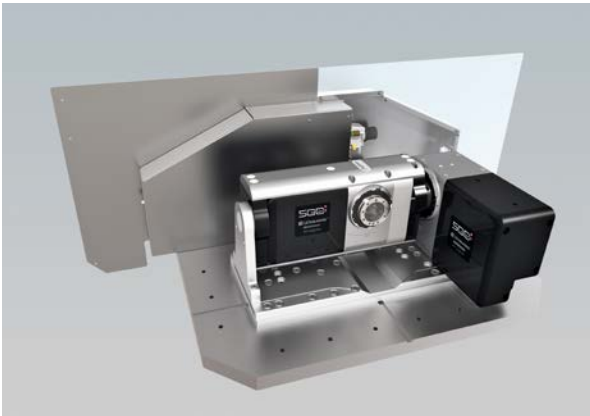

Front view

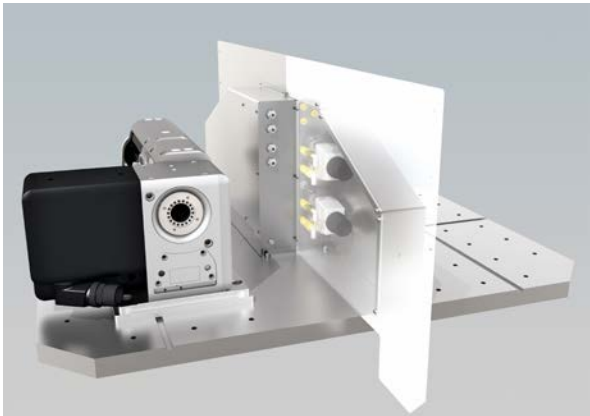

Rear view

Terminal box for Quicktable machines



Assembly kit for Fixtable machines



Practical additional benefits and assembly details

Delivery servoPACK:

- Servos, cables, plates, adapter, etc.
- Parameter lists

Important information (applies to all machines): Per axis, 3 (divider) and 5 (swiveller / tilter) digital inputs as well as 1 digital output per axis are required so that the spindle clamping signals «clamped/released» can be queried properly.

Relay unit

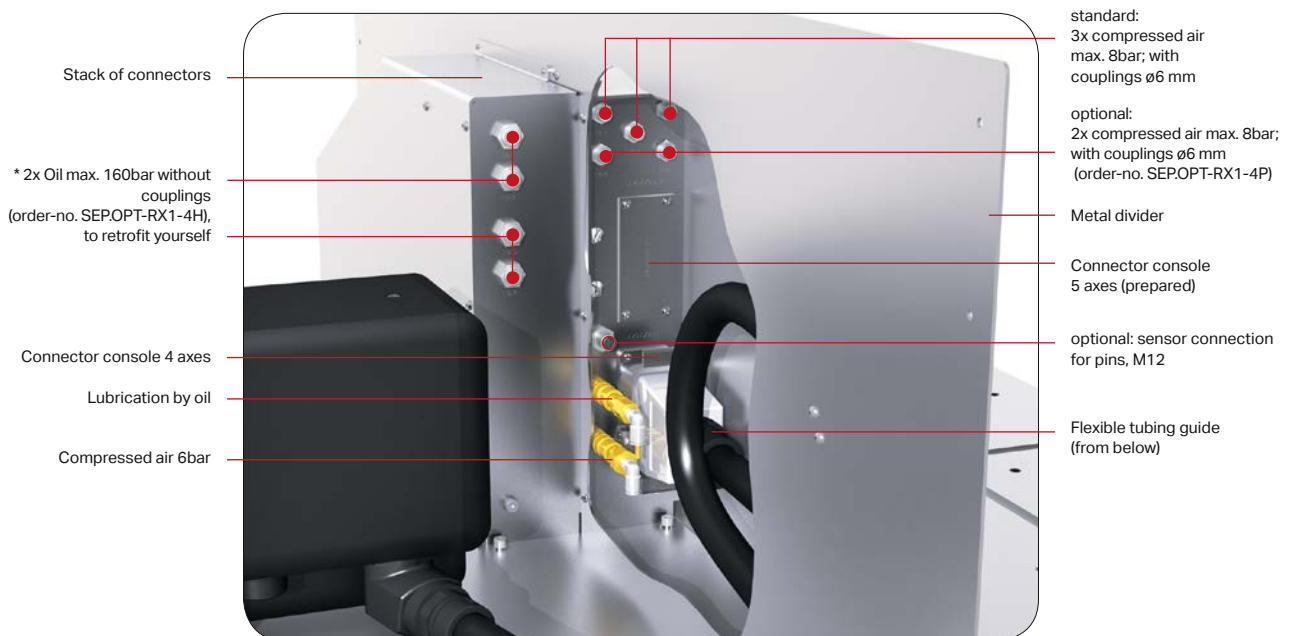

* Remarks

- air pressure and oil pressure can be combined, if 4th axis are mounted on both sides only
- dependence on other combinations, 4x oil per side pressure as option available (on demand)

Assembly process (Example: SPEEDIO R650X2; for details see Commissioning Instructions)





SPEEDIO F600X1



SPEEDIO R450X2



SPEEDIO R650X2

A word from Brother:

«At your side

The Brother Group's mission is to place our customers first everywhere, every time, and provide them with superior value, by quickly creating and delivering high quality products and services. We offer products and services with our distinctive expertise in a wide range of fields.»



SPEEDIO S300X1



SPEEDIO S500X1



SPEEDIO S700X1



SPEEDIO S1000X1

The right machine/rotary table combination for economical production: this Selection Guide helps you make the right selection

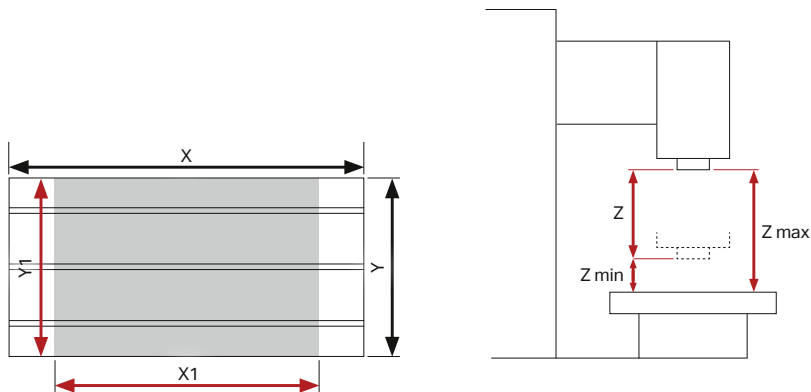

	Table diameter [mm]		Permissible overhang *	Traverse stroke [mm]					Table load ** max [kg]
	X	Y		X1	Y1	Z	Zmin	Zmax	
SPEEDIO F600X1	800	400	30%	600	400	350	200	550	400
SPEEDIO R450X2	600	300	10%	450	320	305	200	505	120
SPEEDIO R650X2	800	400	10%	650	400	305	250	555	200
SPEEDIO S300X1	600	400	30%	300	400	300	180	480	250
SPEEDIO S500X1	600	400	30%	500	400	300	180	480	250
SPEEDIO S700X1	800	400	30%	700	400	300	180	480	250
SPEEDIO S1000X1	1'100	500	30%	1'000	500	300	180	480	300

* The recommended rotary tables can overhang the machine table by so many % (e.g. 10 % means: the rotary table length can be greater than dimension Y or X by max. 10 % of the machine width Y with Y-clamping or 10 % of the table length X with X-clamping.)

** The recommended rotary tables do not exceed 50 % of the allowed table load.

Attention: SPEEDIO R650 has a hole pattern instead of T-slots

SANYO drive system

Criterion	SPEEDIO S300X1	SPEEDIO S500X1	SPEEDIO F600X1	SPEEDIO S700X1	SPEEDIO S1000X1	SPEEDIO R450X2	SPEEDIO R650X2
Machine table slot distance [mm]	100	100	100	100	125	100	
Number of slots / groove width	3/14	3/14	3/14	3/14	3/14	3/12	
Slot distance over alignment tenon blocks [mm]	-	-	-	-	-	-	100

Quicktable machines

Table explanation for pp. 12–15

	EA-507 X2	EA-510 X2	EA-520 X2	EA-530 X2
SPEEDIO F600X1	533	517	491	

Wherever values are listed, the combination is recommended. Empty cells mean that a combination is not possible, because the rotary table is too large, or is not recommended, because the rotary table is disproportionately small or heavier than 50% of the table load.

Machine table and room dimensions of all **brother**-compact machining centers

Speedio F600X1

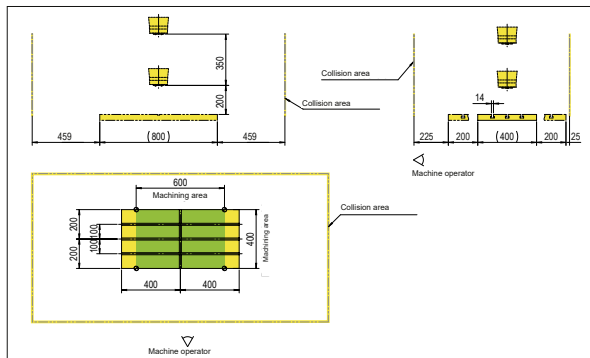

Speedio S300X1

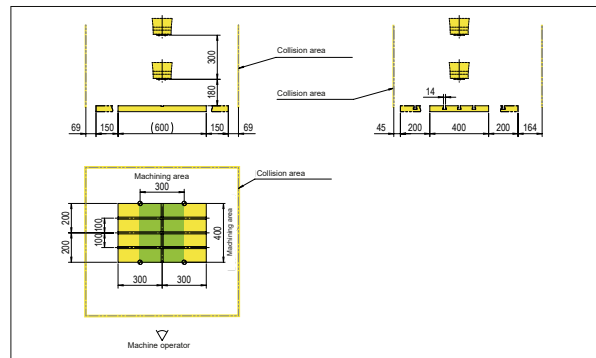

Speedio S500X1

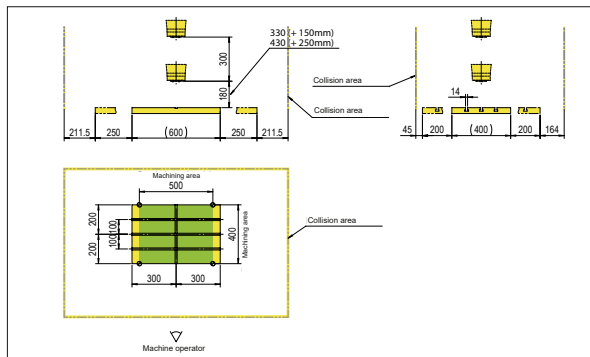

Speedio S700X1

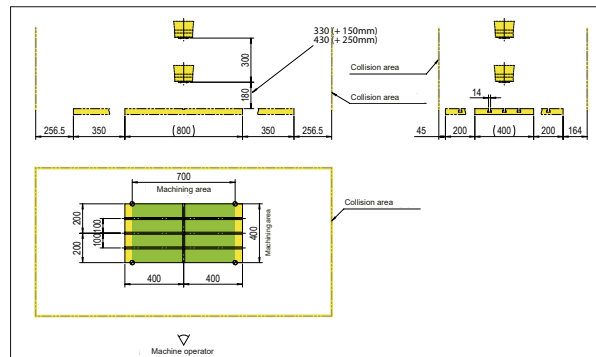

Speedio S1000X1

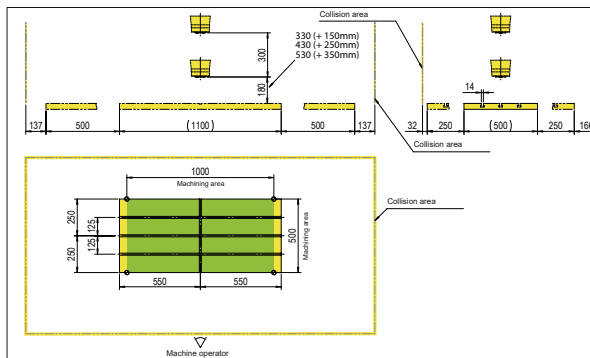

Machine table and room dimensions of all **brother**-compact machining centers

Speedio R450X2

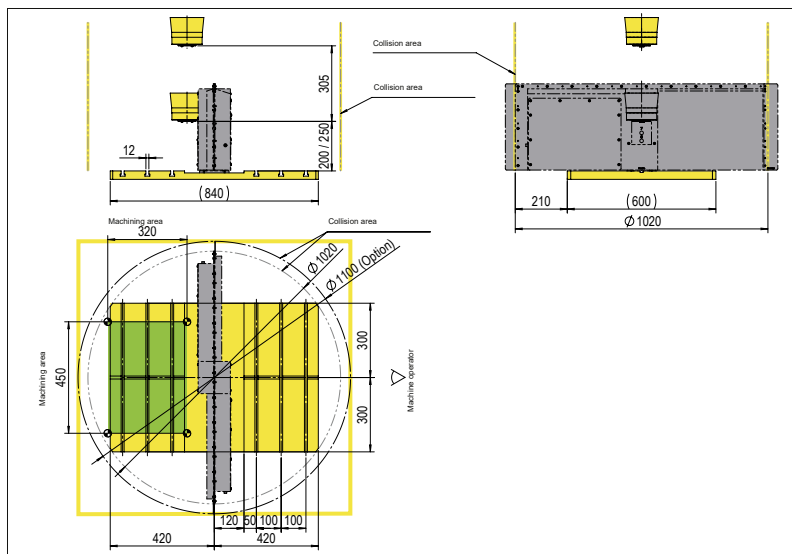

Speedio R650X2

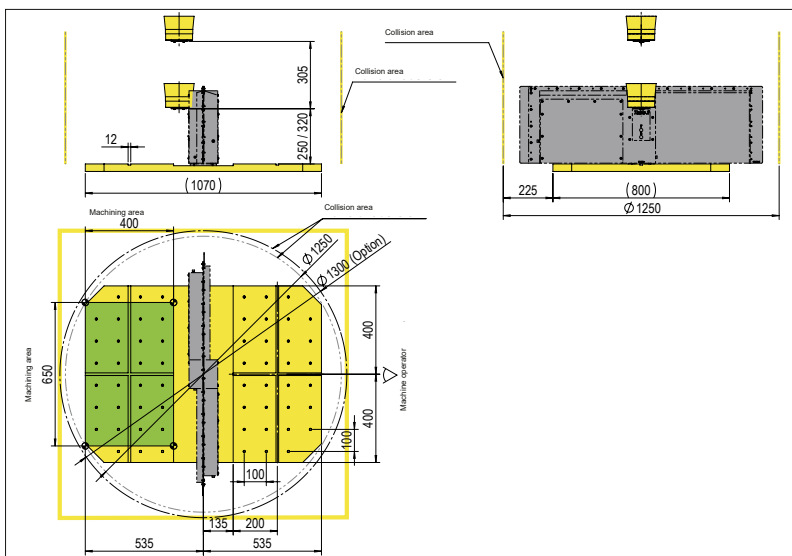

X-mounting

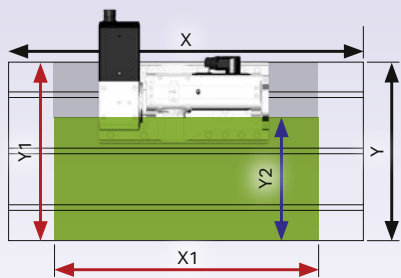

Rotary table installation using hole pattern in base plate



TIP1

TAP1

TOP1.2

	TIP1c TF-507510 Y2	TIP2c TF-510520 Y2	TIP3c TF-520530 Y2	TAP1c T1-507510 Y2	TAP2c T1-510520 Y2	TAP3c T1-520530 Y2	TAP1 T1-507510 Y2	TAP2 T1-510520 Y2	TAP3 T1-520530 Y2	TOP1 T1-507510 Y2
SPEEDIO F600X1		226	206		210		230	210		230
SPEEDIO R450X2	180									
SPEEDIO R650X2	270	226		230			230			230
SPEEDIO S300X1		226					230			230
SPEEDIO S500X1		226					230			230
SPEEDIO S700X1		226					230			230
SPEEDIO S1000X1										

	TOP2 T1-510520 Y2	TOP3 T1-520530 Y2	TAP1c.2 T1-507510 Y2	TAP2c.2 T1-510520 Y2	TAP3c.2 T1-520530 Y2	TAP1.2 T1-507510 Y2	TAP2.2 T1-510520 Y2	TAP3.2 T1-520530 Y2	TOP1.2 T2-507510 Y2	TOP2.2 T2-510520 Y2	TOP3.2 T2-520530 Y2
SPEEDIO F600X1	210		230	210		230	210		230		
SPEEDIO R450X2											
SPEEDIO R650X2			230			230			230		
SPEEDIO S300X1			230								
SPEEDIO S500X1			230								
SPEEDIO S700X1			230			230			230		
SPEEDIO S1000X1			330	310		330			330		



Very good accessibility, even with short tools

More space for workpieces and fixtures

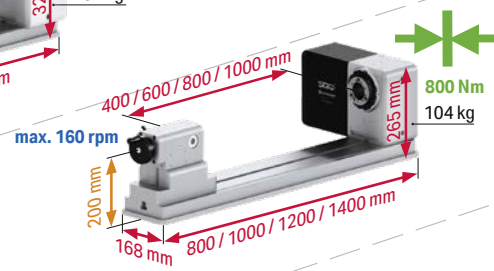
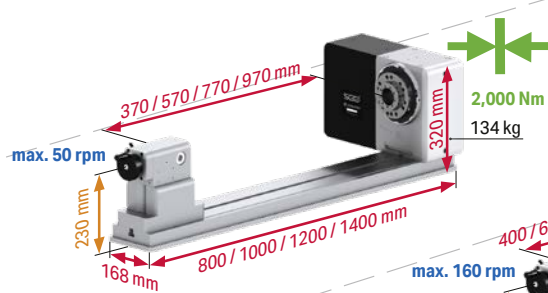
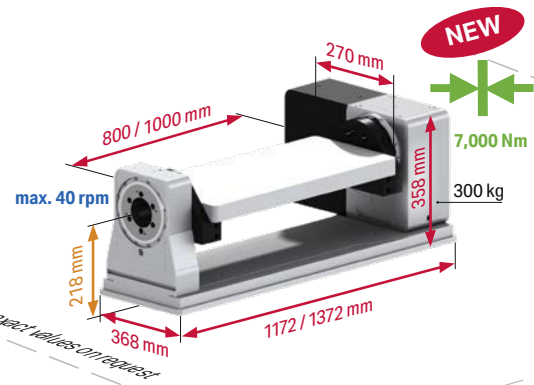
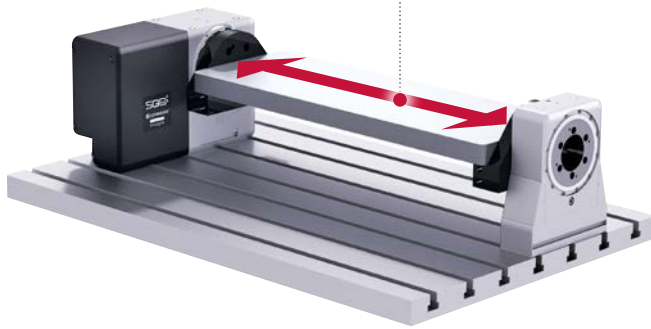

530

520

51x

50x

SIZE

News in brief

1. High speed up to **210 rpm**
2. Feed torque up to **850 Nm** (tentative)
3. Steel base plates with hole pattern (suitable for slot spacing of 100 and 125 mm)
4. Cycle time **90°** as fast as **0.21 sec.**

 Weight data represent the standard load; higher weights possible, but require modification of rotational speed, acceleration and jerk limitation.

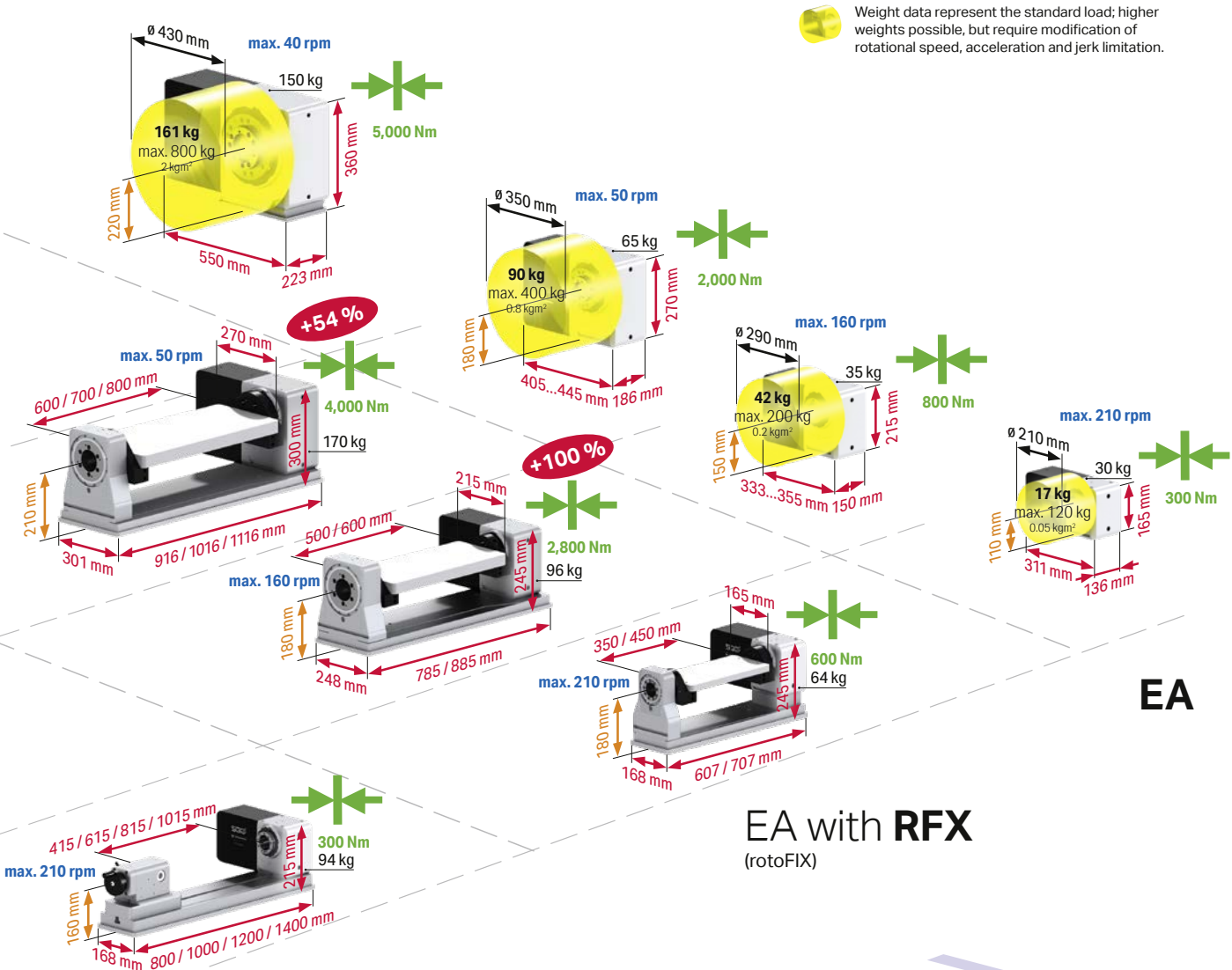

EA

EA with **RFX**
(rotoFIX)

EA with **LFX**
(longFLEX)

MODEL

- 50x 507 (standard) or 508 (high speed)
- 51x 510 (standard) or 511 (high speed)
- EA single-axis, single-spindle CNC rotary table
- rotoFIX modular clamping yoke system
- longFLEX modular shaft clamping system

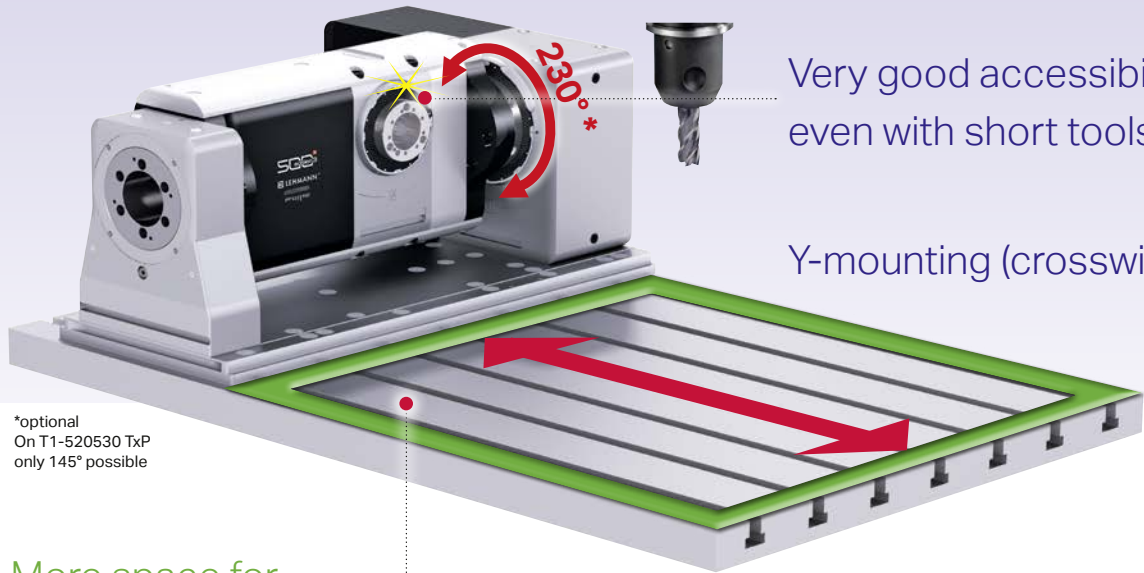

Very good accessibility, even with short tools

Y-mounting (crosswise)

*optional
On T1-520530 TxP
only 145° possible

More space for workpiece and fixtures

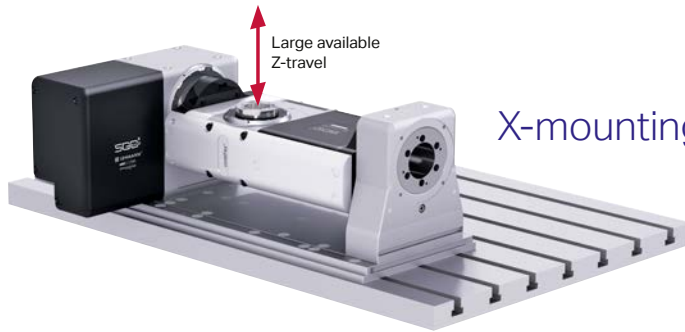

Large available Z-travel

X-mounting (lengthwise)

T1

T1

T1

TF

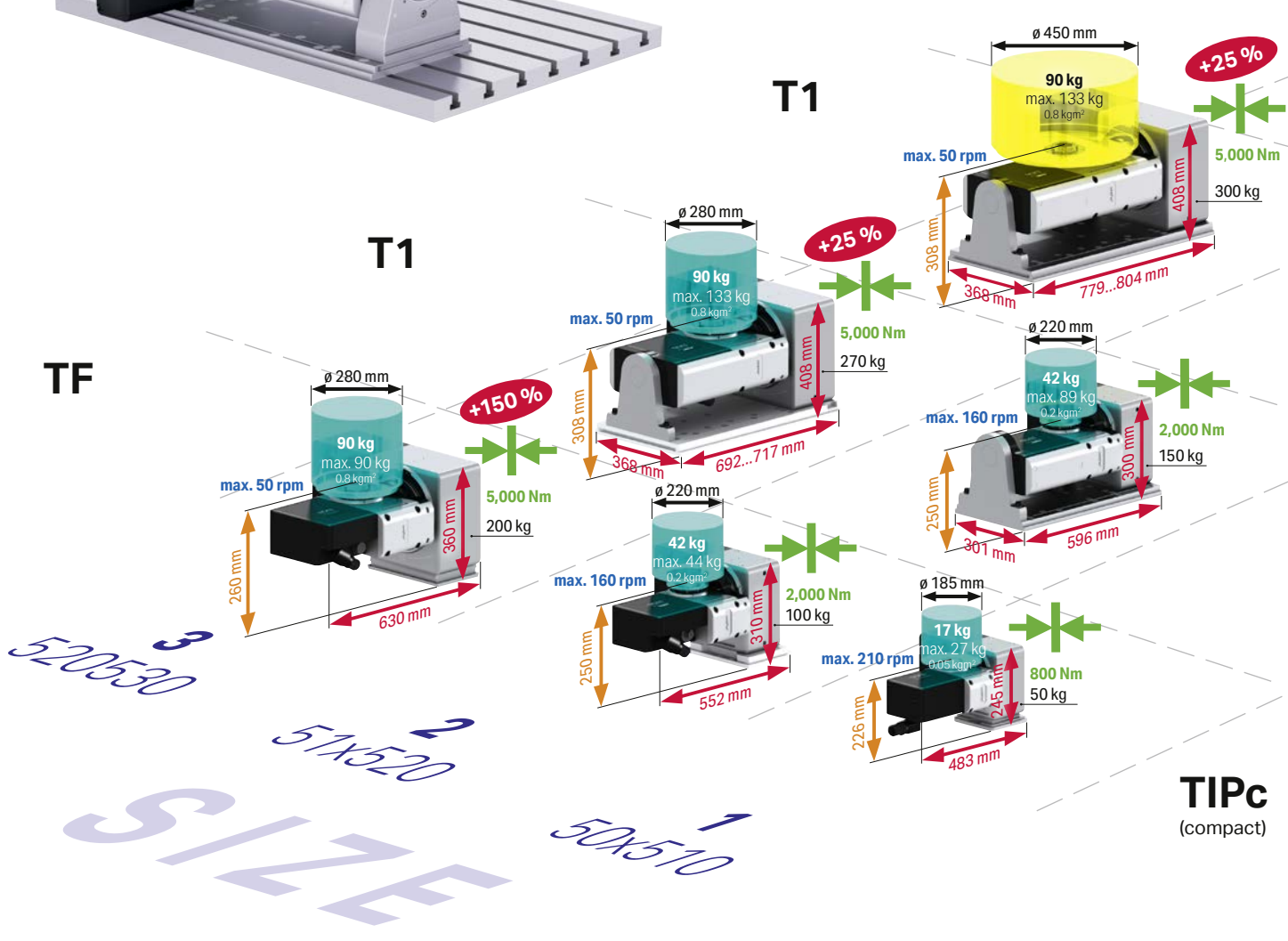

TIPc
(compact)

SIZE

News in brief

1. Up to 150% higher clamping torque in tilting axis
2. Fewer variant – more solution
3. Larger workpiece \varnothing possible
4. Spatially optimized arrangement of the dividing axis

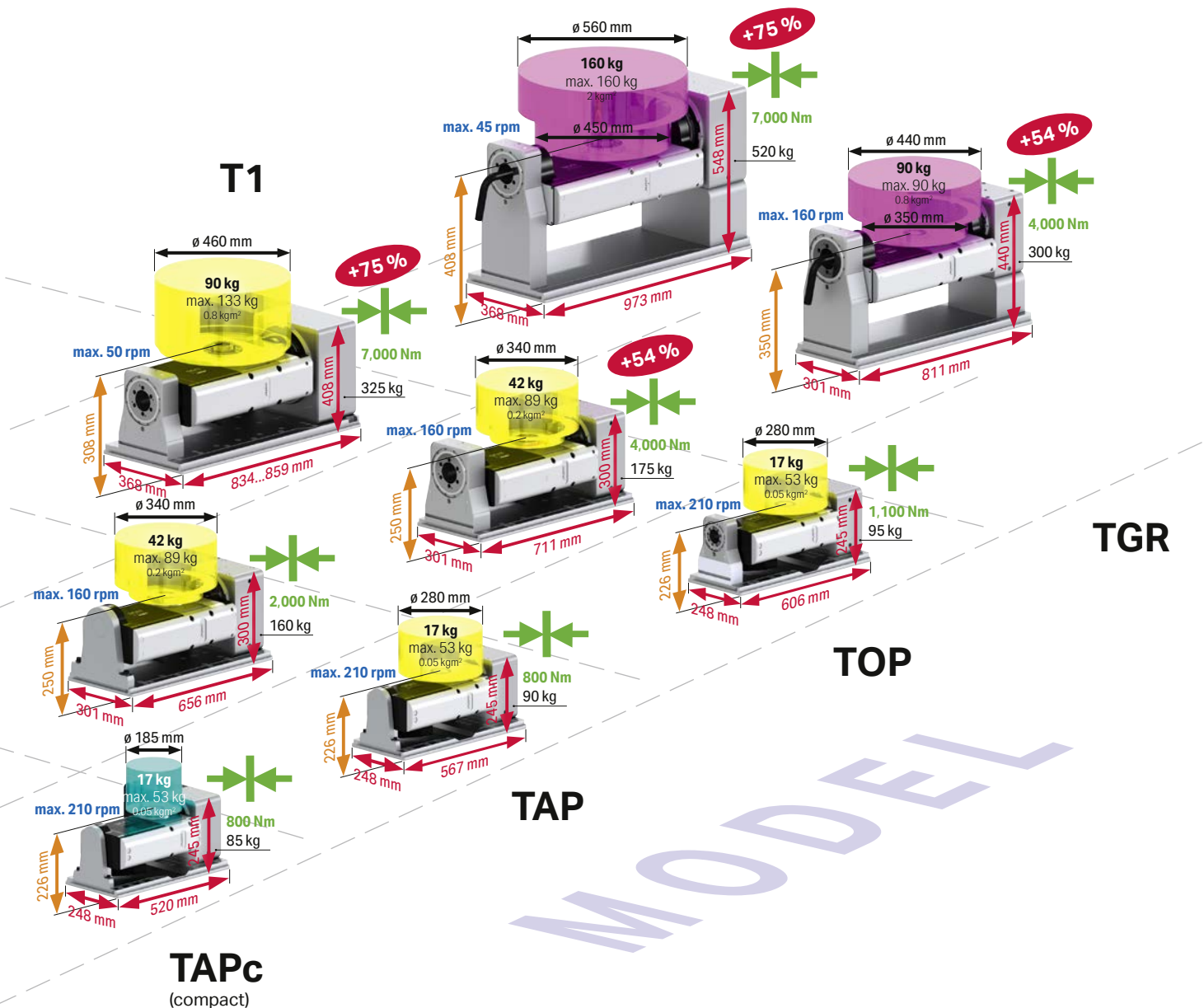

Weight data represent the standard load; higher weights possible, but require modification of rotational speed, acceleration and jerk limitation.

- 50x510 508510 (standard) or 508510 (high speed)
- 51x520 510520 (standard) or 511520 (high speed)
- TIPc Two-axis rotary table, no counter bearing, compact
- TAPc Two-axis rotary table, with supporting bearing, compact
- TAP Two-axis rotary table, with supporting bearing
- TOP Two-axis rotary table, with clamped counter bearing
- TGR Two-axis rotary table, with clamped counter bearing, specifically for grinding applications



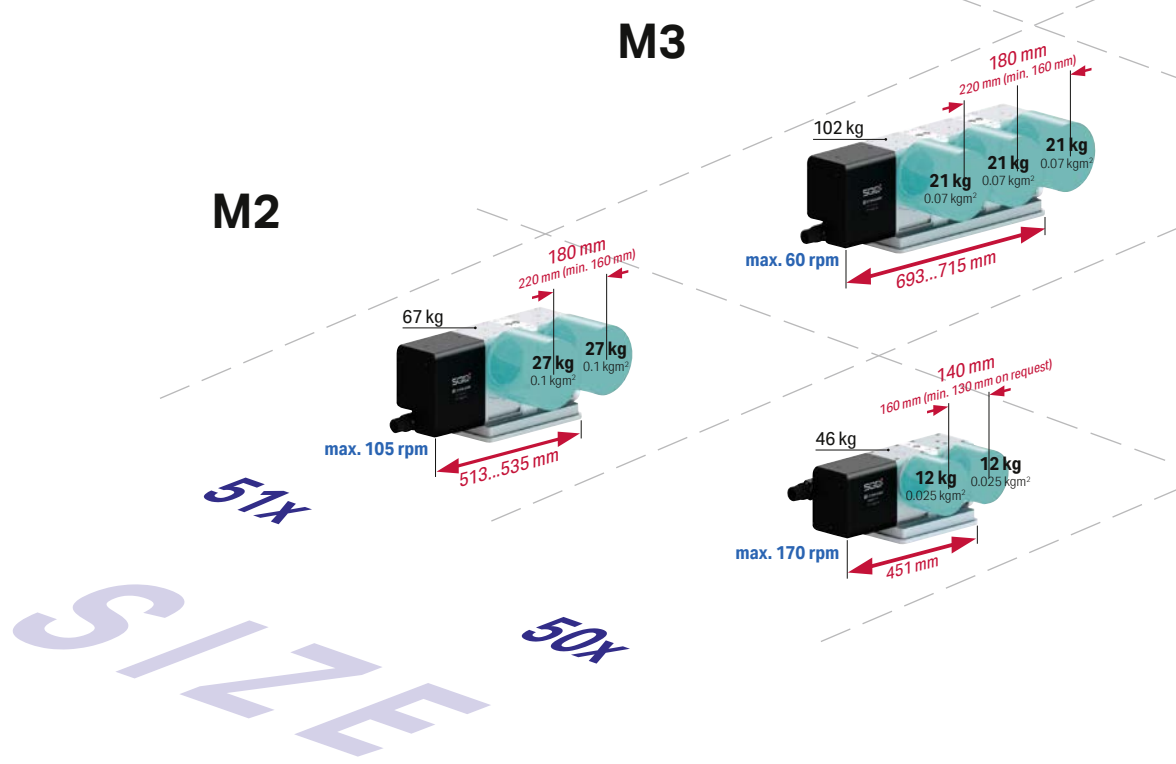

More space for workpiece and fixtures

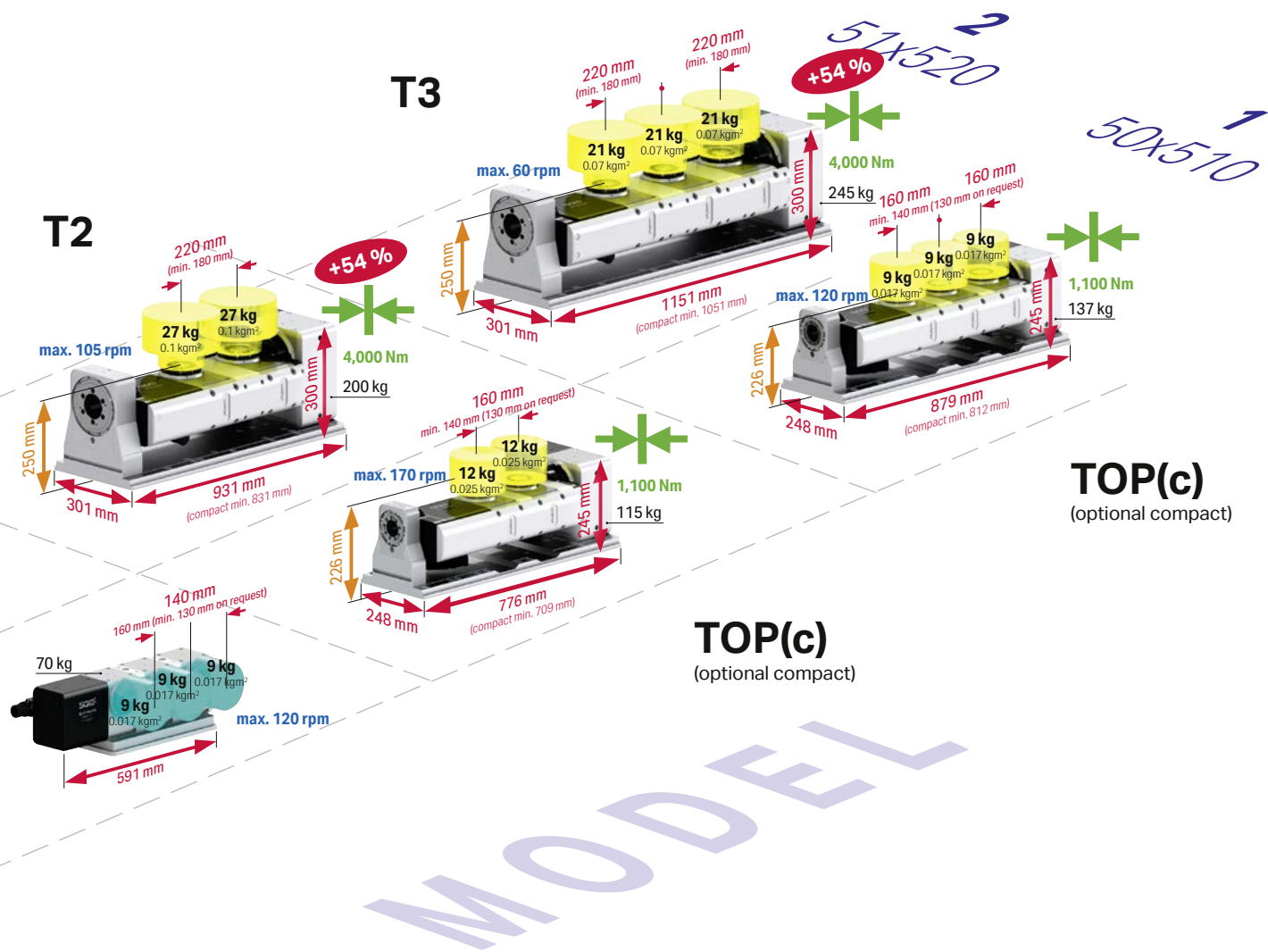

News in brief

1. Up to **54 %** higher clamping torque in tilting axis
2. Fewer variant – more solution
3. Spindle distance min. **130 mm**
4. Spatially optimized arrangement of the dividing axis



 Weight data represent the standard load; higher weights possible, but require modification of rotational speed, acceleration and jerk limitation.

- 50x 507 (standard) or 508 (high speed)
- 51x 510 (standard) or 511 (high speed)
- M2 Single-axis, multi-spindle rotary table, 2-position
- M3 Single-axis, multi-spindle rotary table, 3-position
- T2 Two-axis multi-spindle rotary table, 2-position
- T3 Two-axis multi-spindle rotary table, 3-position

Extremely wide assortment for workpiece clamping.
Standardized interface in front and rear: maximum universality

Spindle accessories in rear

- + Rotary unions **up to 250 bar**
- + Clamping cylinder **23 kN at 120 bar**
- + Angular position measuring systems **as precise as ± 1 arcsec**



Spindle accessories in front



Tailstock and counter bearing



ripas zero point clamping system



EA-507 with ripas auto and ripas adapter

CAPTO clamping (on request)



EA-507 with CAPTO retrofit kit

Present in over 20 countries: from sales consultation to the final service



Services from A to Z

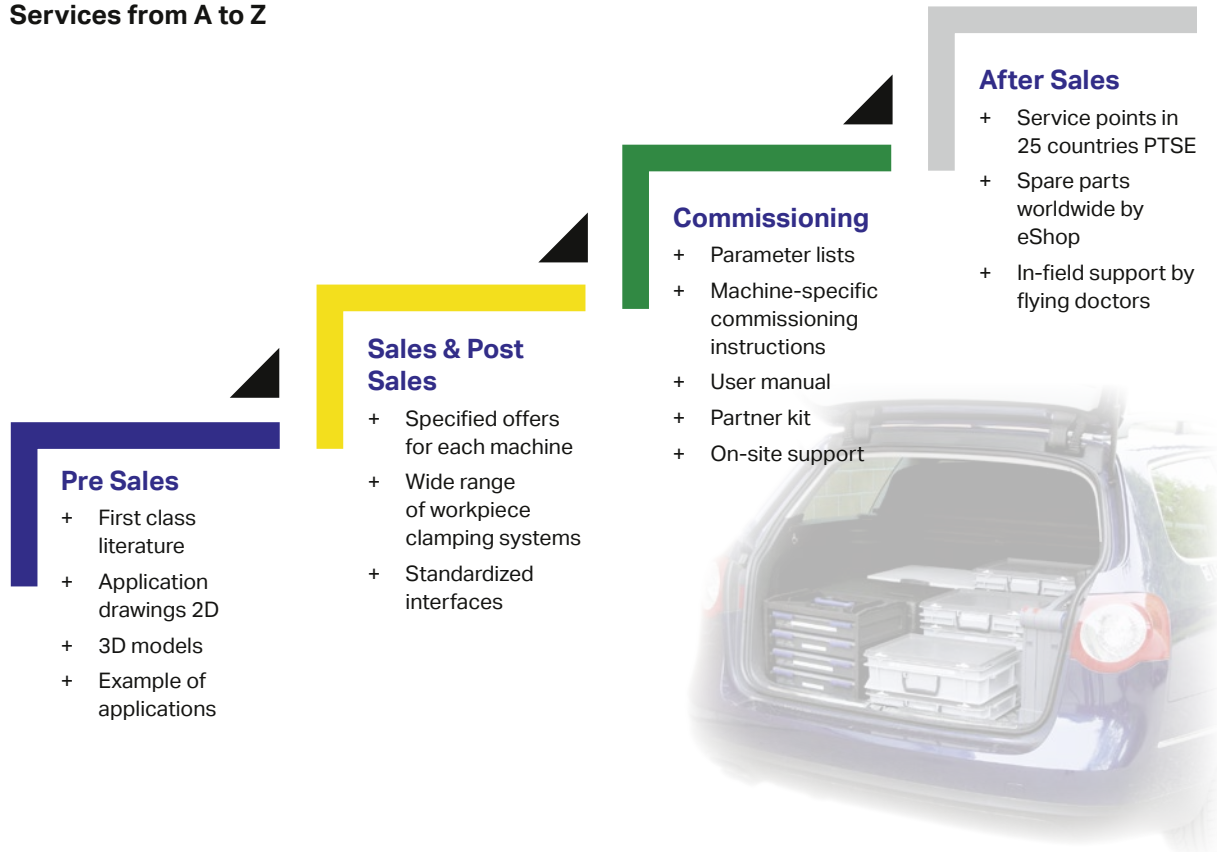

Increase productivity – Extend lifecycle

Comprehensive and professional services throughout the product life cycle – maximum availability with consistent quality and high productivity.

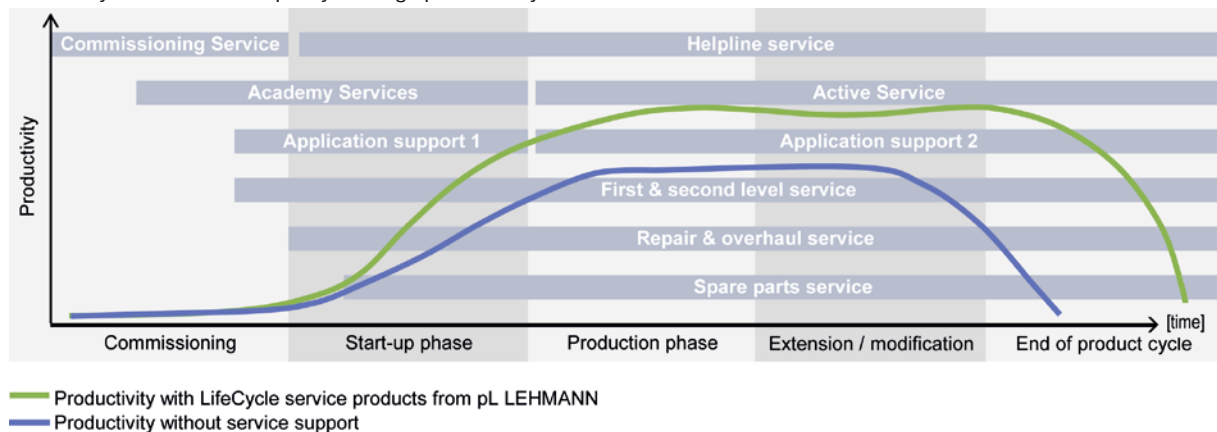

For more information please see www.lehmann-rotary-tables.com.



ROTARY TABLES · PRECISION TECHNOLOGY · SOFTWARE

Headquarters

PETER LEHMANN AG
CH-3552 Bârau
Phone +41 (0)34 409 66 66
Fax +41 (0)34 409 66 00
pls@plehmann.com
www.lehmann-rotary-tables.com

Representatives / Agencies

Europe

- Austria
- Benelux
- Czech Republic (vacant)
- Finland
- France
- Germany
- Hungary (vacant)
- Italy
- Norway
- Poland
- Portugal
- Russia
- Slovenia
- Spain
- Sweden
- Turkey
- UK

America

- Brazil
- Canada
- Mexico
- USA

Asia

- China
- India
- Japan
- Malaysia
- Singapore
- South Korea
- Taiwan
- Thailand
- Vietnam

Africa

- South Africa

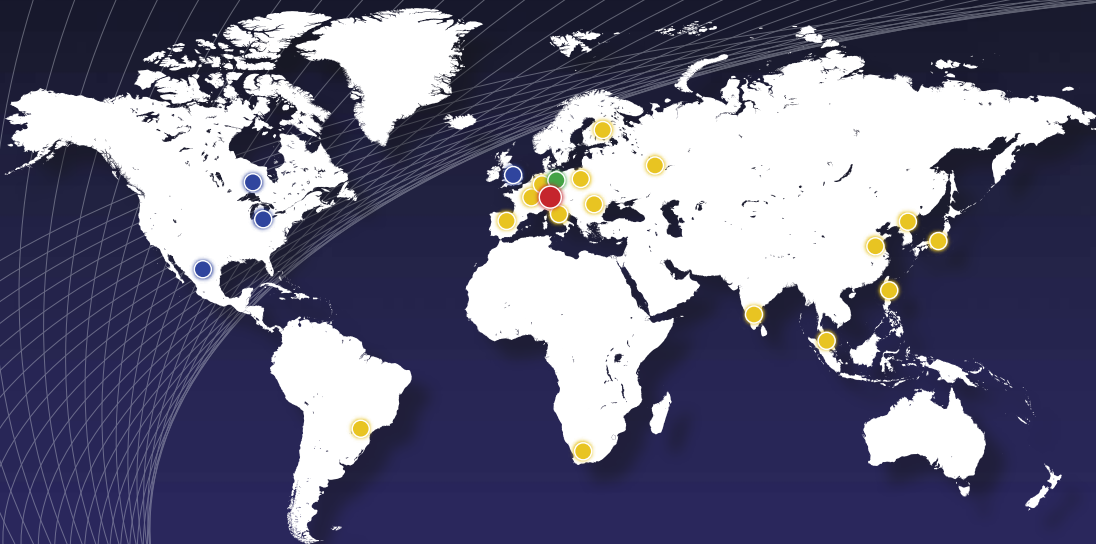

● Headquarters ● direct sales partner ● pL Solutions® partner ● value added reseller & partner

More information (address, telephone number...) at www.lehmann-rotary-tables.com