



# Selection Guide for CNC Rotary Tables ...



Bluetooth®

pl

 BRIDGEPORT

10/2018 | EN



... for GX- and XR-series

CNC rotary tables for economical manufacturing:  
pL LEHMANN has suitable and rational solutions for  
nearly every industry

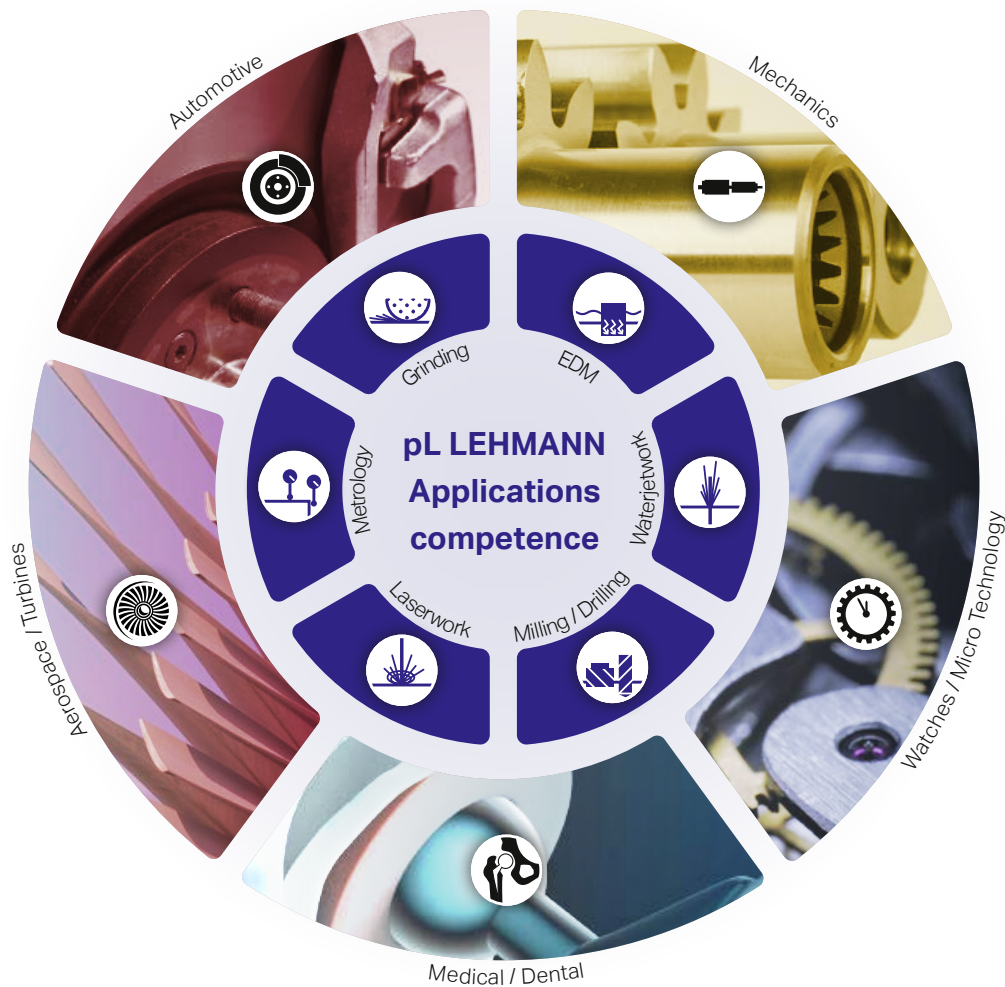

pL rotary tables in use: on over **40** different machine brands  
and over **160** different machine models.

pL competence: Integration in **all known** CNC control systems  
(Fanuc, Siemens, Heidenhain, Haas, Winmax, Mitsubishi, Brother,  
Mazatrol, Okuma ...), for new machines as well as for retrofits

Professional products from professional partners:  
BRIDGEPORT and pL LEHMANN provide  
first-class service to common customers

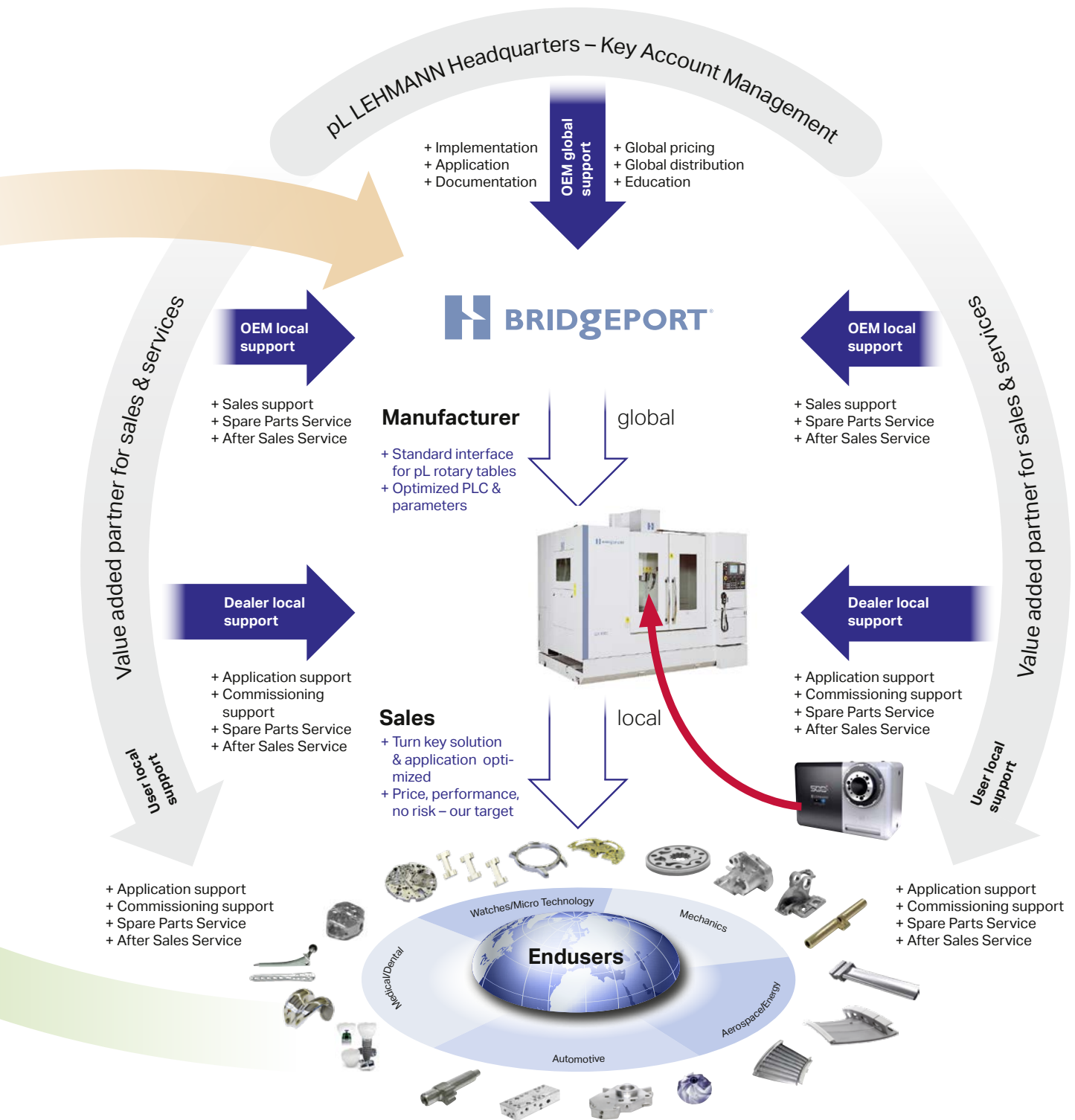

**NEW**  
up to +30 %

Up to **210 rpm**  
up to **0.21 sec / 90°**

Extended travel in  
Z- and X-direction

High spindle load,  
heavy-duty bearing

**High speed**

**More space**

**Heavy duty**

## E-Series



**Rotary tables suitable for simultaneous operation!**

### Save energy

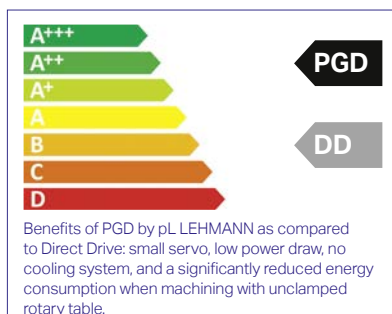

**Energy label at the left**  
An intuitive rating as consumption greatly depends on usage, and without any liability assumed, following the directives on energy labelling

**See main catalog for more features**

**NEW**  
up to +30 %

**High torque**

Feed torque up to  
**850 Nm** (provisional)

**Adaptability**

Multifunctional  
spindle HSK

**Precision**

On the workpiece, as  
precise as **2 µm / 100 mm**

**NEW**  
up to +150%

Pneum. clamping  
up to 7,000 Nm

**High clamp**

Large parts  
up to  $\varnothing$  500

**Big size**

PGD backlash-free  
long-life gear unit

**No backlash**

## T-Series



**All base plates  
made of steel**

**NEW**

with integrated hole pattern for  
slot spacing of 100 and 125 mm,  
integrated alignment system  
**lineFIX** for lengthwise or cross-  
wise clamping.

## M-Series



**NEW**

**Connectivity**

Wireless monitoring,  
for operation & service

**No adjust**

Load change without  
parameter adjustment

**Less cost**

No cooling system,  
no hydraulics



GX 300



GX 1000



XR 760



XR 1600

## A word from BRIDGEPORT:

### «Competitive performance

Over the past 10 years, Hardinge Inc. steadily diversified both its offerings and operations. Today, the company has grown into a globally diversified player; with manufacturing operations in the U.S., U.K., Switzerland, China and Taiwan. In addition to designing and building turning centers and collets, Hardinge is a world leader in grinding solutions.»

The right machine/rotary table combination for economical production: this Selection Guide helps you make the right selection

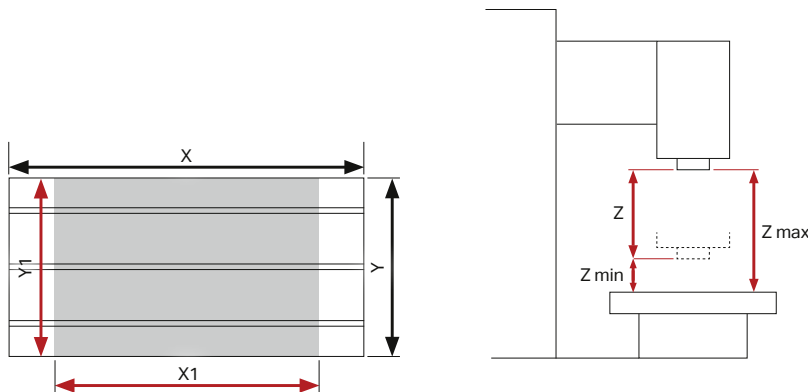

	Table diameter [mm]		Permissible overhang *	Traverse stroke [mm]					Table load ** max [kg]
	X	Y		X1	Y1	Z	Zmin	Zmax	
GX 300	600	400	10%	300	400	430	150	580	180
GX 480	600	400	10%	480	400	430	150	580	300
GX 510	600	400	10%	510	400	430	150	580	250
GX 710	800	400	10%	710	400	430	150	580	300
GX1000	1'120	540	10%	1'020	540	540	145	685	800
GX1300 (-50)	1'425	700	10%	1'300	700	635	133	768	1'500
GX1600 (-50)	1'700	700	10%	1'600	700	635	133	768	1'500
XR 760	1'000	600	10%	760	610	610	100	710	700
XR 1000	1'200	600	10%	1'020	610	610	100	710	980
XR 1300	1'420	700	10%	1'300	700	635	133	768	1'500
XR 1600	1'700	700	10%	1'600	700	635	133	768	1'500

\* The recommended rotary tables can overhang the machine table by so many % (e.g. 10 % means: the rotary table length can be greater than dimension Y or X by max. 10 % of the machine width Y with Y-clamping or 10 % of the table length X with X-clamping.)  
 \*\* The recommended rotary tables do not exceed 50 % of the allowed table load.

Table explanation for pp. 8-11

	EA-507 X2	EA-510 X2	EA-520 X2	EA-530 X2
GX 300	283	267	241	

Wherever values are listed, the combination is recommended. Empty cells mean that a combination is not possible, because the rotary table is too large, or is not recommended, because the rotary table is disproportionately small or heavier than 50% of the table load.

For further details about the rotary tables, see p. 12 and higher or refer to the main catalog



	EA-507 X2	EA-510 X2	EA-520 X2	EA-530 X2
GX 300	283	267	241	
GX 480	373	357	331	
GX 510	388	372	346	
GX 710	588	572	546	
GX1000	903	887	861	832
GX1300 (-50)			1'154	1'125
GX1600 (-50)			1'441	1'412
XR 760	713	697	671	642
XR 1000	943	927	901	872
XR 1300			1'151	1'122
XR 1600			1'441	1'412

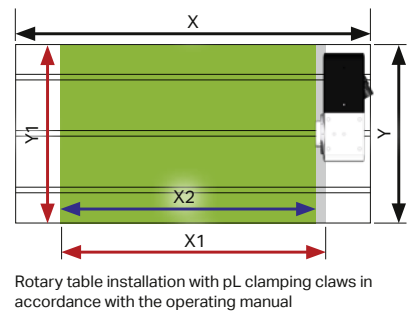

### Clamping yokes for EA-type rotary tables

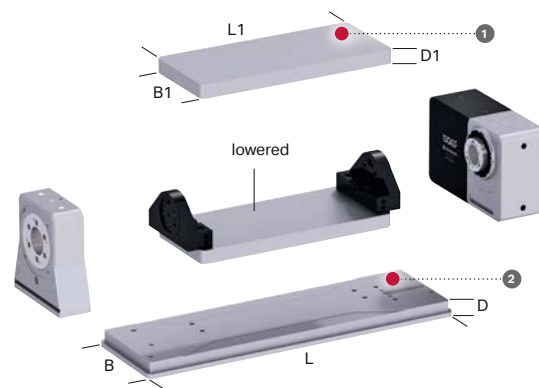

			EA-507	EA-510	EA-520	EA-530
<b>1 Clamping yokes</b>	Sph	[mm]			210	218
	Length L1	[mm]			600	700 800
	Width B1	[mm]				270
	Thickness D1	[mm]				40
<b>2 Base plates</b>	Length L	[mm]	916	1016	1116	1172 1372
	Width B	[mm]		301		368
	Thickness D	[mm]		30		38
<b>Weights / moments of inertia</b> (without rotary table, without counter bearing)	Weight (Al)	[kg]			40	45 52
	Weight (steel)	[kg]			117	130 152
	Mom. inert. (Al)	[kgm <sup>2</sup> ]			0.16	0.17 0.21
	Mom. inert. (steel)	[kgm <sup>2</sup> ]			0.46	0.50 0.60
on request						



## Explanations for pp. 8 to 11

The recommendations are for information purposes only. We recommend that you verify the effective dimensions prior to ordering. Modifications on the machine can lead to collisions and affect the dimensions X2 and Y2.



	M2-507	M2-510	M3-507	M3-510
	X2			
GX 300				
GX 480				
GX 510				
GX 710				
GX1000	844	834	844	
GX1300 (-50)	1'137	1'127	1'137	1'127
GX1600 (-50)	1'424	1'414	1'424	1'414
XR 760	654	644	654	
XR 1000	884	874	884	
XR 1300	1'134	1'124	1'134	1'124
XR 1600	1'424	1'414	1'424	1'414

### Y-mounting

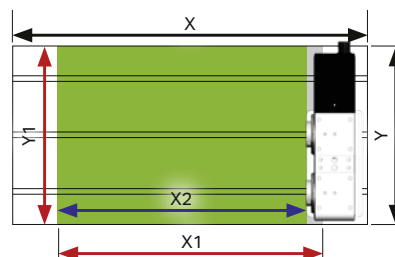

Rotary table installation with pL clamping claws in accordance with the operating manual

	M2-507	M2-510	M3-507	M3-510
	Y2			
GX 300	174	164	174	
GX 480	174	164	174	
GX 510	174	164	174	
GX 710	174	164	174	164
GX1000				304
GX1300 (-50)				
GX1600 (-50)				
XR 760				369
XR 1000				369
XR 1300				
XR 1600				

### X-mounting

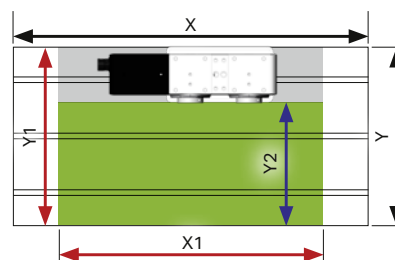

Rotary table installation with pL clamping claws in accordance with the operating manual

## Y-mounting

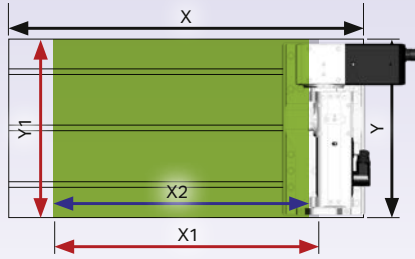

Rotary table installation using hole pattern in base plate



TIP1



TAP1



TOP1.2

	<b>TIP1c</b> TF-507510 X2	<b>TIP2c</b> TF-510520 X2	<b>TIP3c</b> TF-520530 X2	<b>TAP1c</b> T1-507510 X2	<b>TAP2c</b> T1-510520 X2	<b>TAP3c</b> T1-520530 X2	<b>TAP1</b> T1-507510 X2	<b>TAP2</b> T1-510520 X2	<b>TAP3</b> T1-520530 X2	<b>TOP1</b> T1-507510 X2
<b>GX 300</b>										
<b>GX 480</b>										
<b>GX 510</b>										
<b>GX 710</b>										
<b>GX1000</b>	940	896		900			900			
<b>GX1300 (-50)</b>	1'233	1'189	1'169	1'193	1'173	1'139	1'193	1'173		1'193
<b>GX1600 (-50)</b>	1'520	1'476	1'456	1'480	1'460	1'426	1'480	1'460		1'480
<b>XR 760</b>	750	706	686	710	690		710	690		710
<b>XR 1000</b>	980	936	916	940	920		940	920		940
<b>XR 1300</b>	1'230	1'186	1'166	1'190	1'170	1'136	1'190	1'170		1'190
<b>XR 1600</b>	1'520	1'476	1'456	1'480	1'460	1'426	1'480	1'460		1'480

	<b>TOP2</b> T1-510520 X2	<b>TOP3</b> T1-520530 X2	<b>TAP1c.2</b> T1-507510 X2	<b>TAP2c.2</b> T1-510520 X2	<b>TAP3c.2</b> T1-520530 X2	<b>TAP1.2</b> T1-507510 X2	<b>TAP2.2</b> T1-510520 X2	<b>TAP3.2</b> T1-520530 X2	<b>TOP1.2</b> T2-507510 X2	<b>TOP2.2</b> T2-510520 X2	<b>TOP3.2</b> T2-520530 X2
<b>GX 300</b>											
<b>GX 480</b>											
<b>GX 510</b>											
<b>GX 710</b>											
<b>GX1000</b>											
<b>GX1300 (-50)</b>	1'173		1'193			1'193			1'193		
<b>GX1600 (-50)</b>	1'460		1'480			1'480			1'480		
<b>XR 760</b>			710								
<b>XR 1000</b>			940								
<b>XR 1300</b>	1'170		1'190			1'190			1'190		
<b>XR 1600</b>	1'460		1'480			1'480			1'480		

## X-mounting

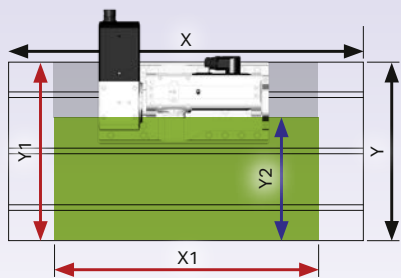

Rotary table installation using hole pattern in base plate



	TIP1c TF-507510	TIP2c TF-510520	TIP3c TF-520530	TAP1c T1-507510	TAP2c T1-510520	TAP3c T1-520530	TAP1 T1-507510	TAP2 T1-510520	TAP3 T1-520530	TOP1 T1-507510
	Y2	Y2	Y2	Y2	Y2	Y2	Y2	Y2	Y2	Y2
GX 300	270			230			230			
GX 480	270	226		230	210		230			230
GX 510	270	226		230			230			230
GX 710	270	226		230	210		230			230
GX1000			346		350	316		350	316	370
GX1300 (-50)									476	
GX1600 (-50)										
XR 760						381			381	
XR 1000						381			381	
XR 1300									476	
XR 1600										

	TOP2 T1-510520	TOP3 T1-520530	TAP1c.2 T1-507510	TAP2c.2 T1-510520	TAP3c.2 T1-520530	TAP1.2 T1-507510	TAP2.2 T1-510520	TAP3.2 T1-520530	TOP1.2 T2-507510	TOP2.2 T2-510520	TOP3.2 T2-520530
	Y2	Y2	Y2	Y2	Y2	Y2	Y2	Y2	Y2	Y2	Y2
GX 300			230								
GX 480			230								
GX 510			230								
GX 710			230	210		230			230		
GX1000	350	316	370	350	316	370	350	316	370	350	
GX1300 (-50)		476		510	476		510	476		510	476
GX1600 (-50)					476		510	476		510	476
XR 760	415	381		415		435	415		435	415	
XR 1000	415	381		415	381	435	415	381	435	415	381
XR 1300		476		510	476		510	476		510	476
XR 1600					476		510	476		510	476



Very good accessibility, even with short tools

More space for workpieces and fixtures

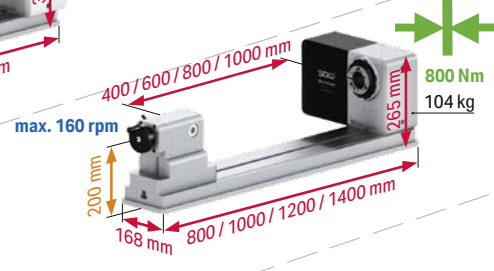
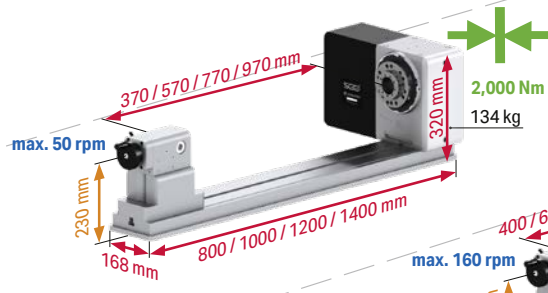
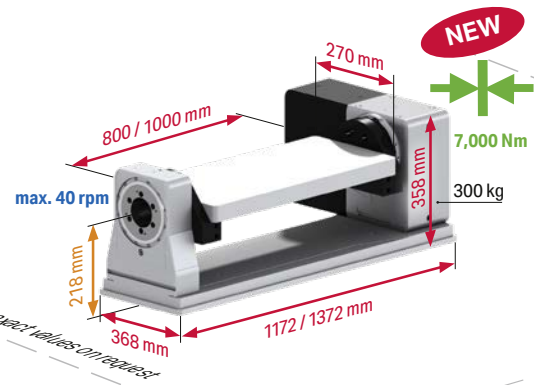
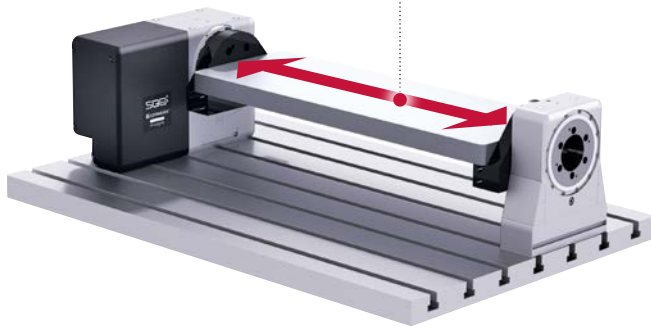

530

520

51x

50x

SIZE

### News in brief

1. High speed up to **210 rpm**
2. Feed torque up to **850 Nm** (tentative)
3. Steel base plates with hole pattern (suitable for slot spacing of 100 and 125 mm)
4. Cycle time **90°** as fast as **0.21 sec.**

 Weight data represent the standard load; higher weights possible, but require modification of rotational speed, acceleration and jerk limitation.

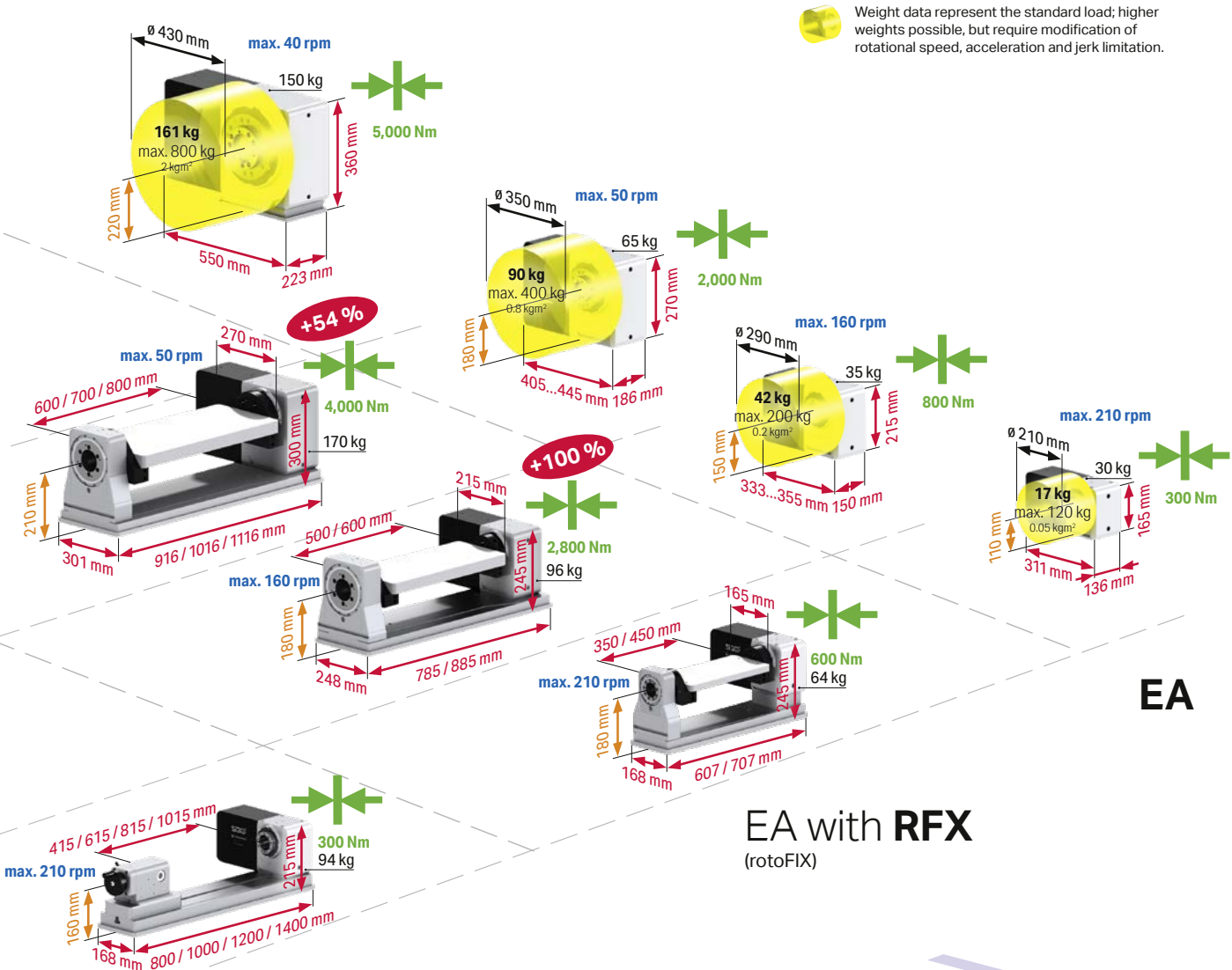

EA

EA with **RFX**  
(rotoFIX)

EA with **LFX**  
(longFLEX)

MODEL

- 50x 507 (standard) or 508 (high speed)
- 51x 510 (standard) or 511 (high speed)
- EA single-axis, single-spindle CNC rotary table
- rotoFIX modular clamping yoke system
- longFLEX modular shaft clamping system

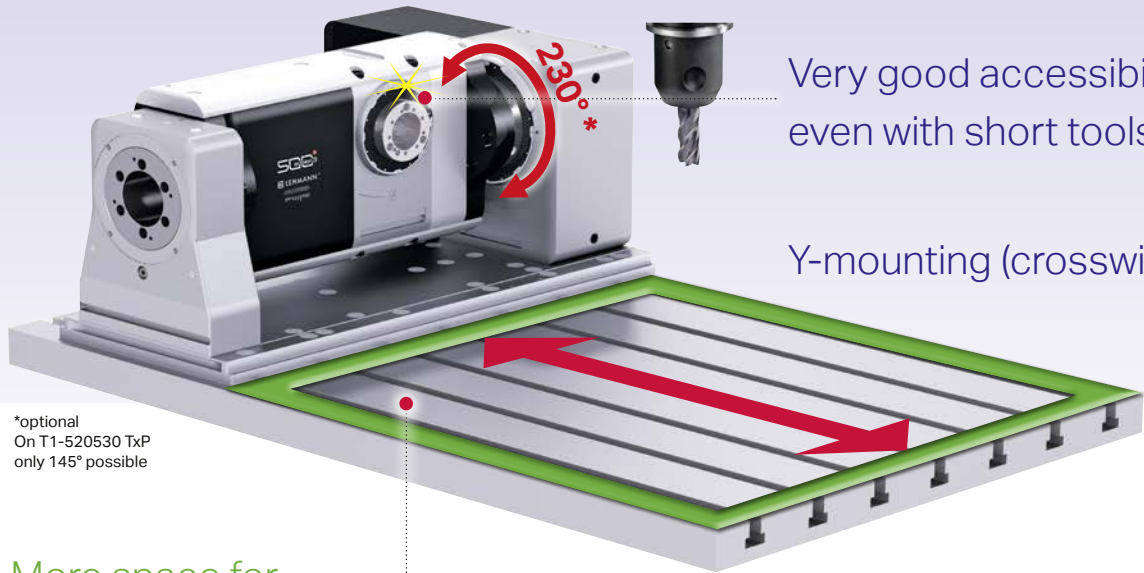

Very good accessibility, even with short tools

Y-mounting (crosswise)

\*optional  
On T1-520530 TxP  
only 145° possible

More space for workpiece and fixtures

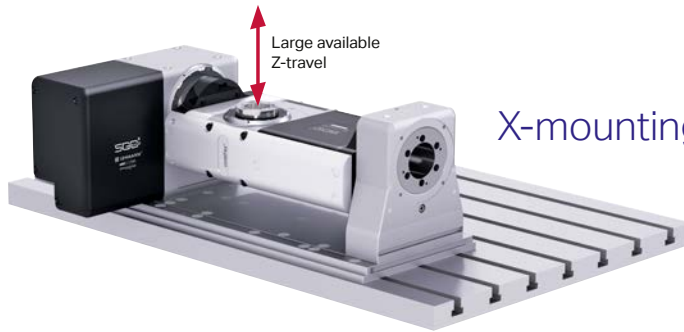

X-mounting (lengthwise)

**T1**

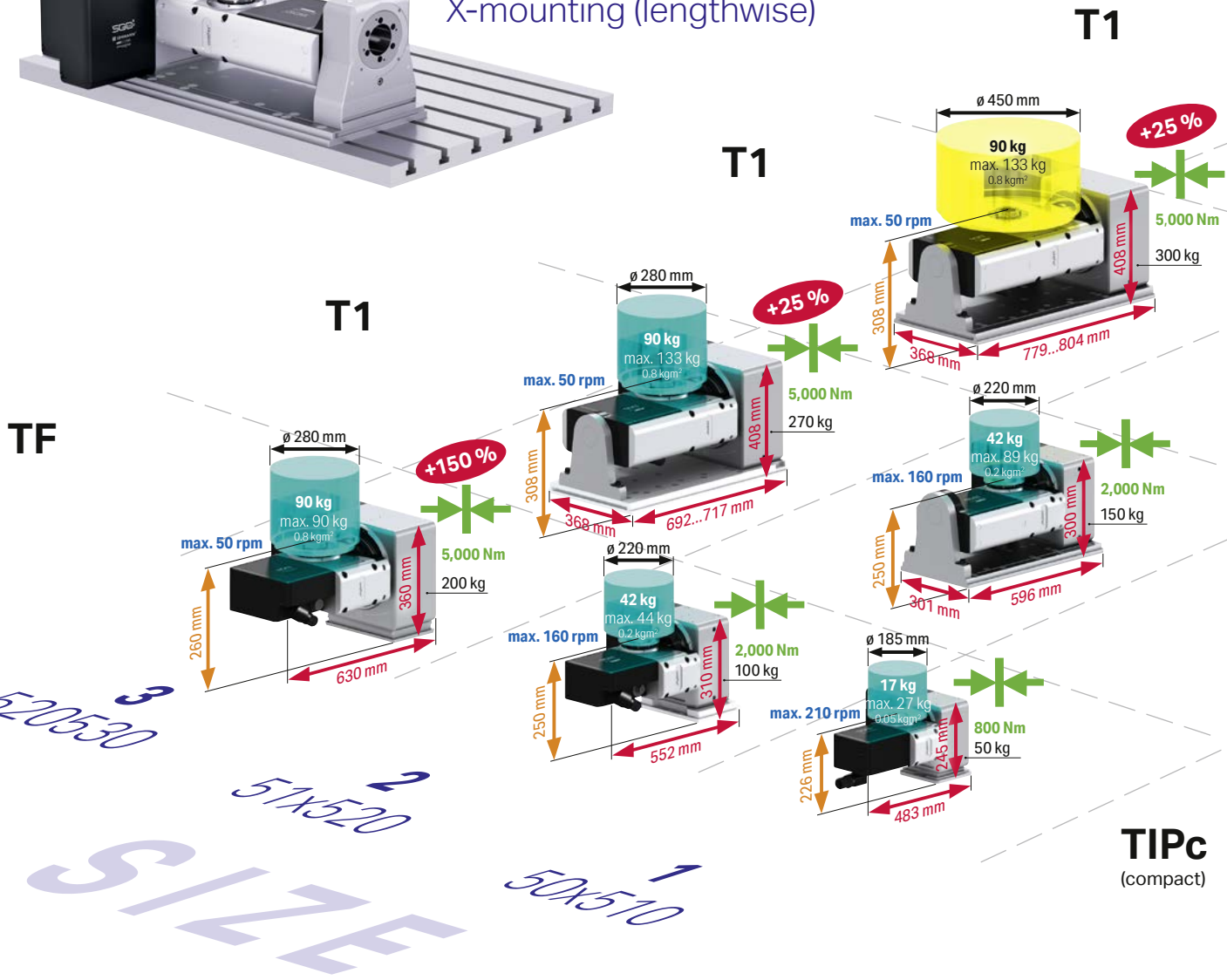

### News in brief

1. Up to 150% higher clamping torque in tilting axis
2. Fewer variant – more solution
3. Larger workpiece  $\varnothing$  possible
4. Spatially optimized arrangement of the dividing axis

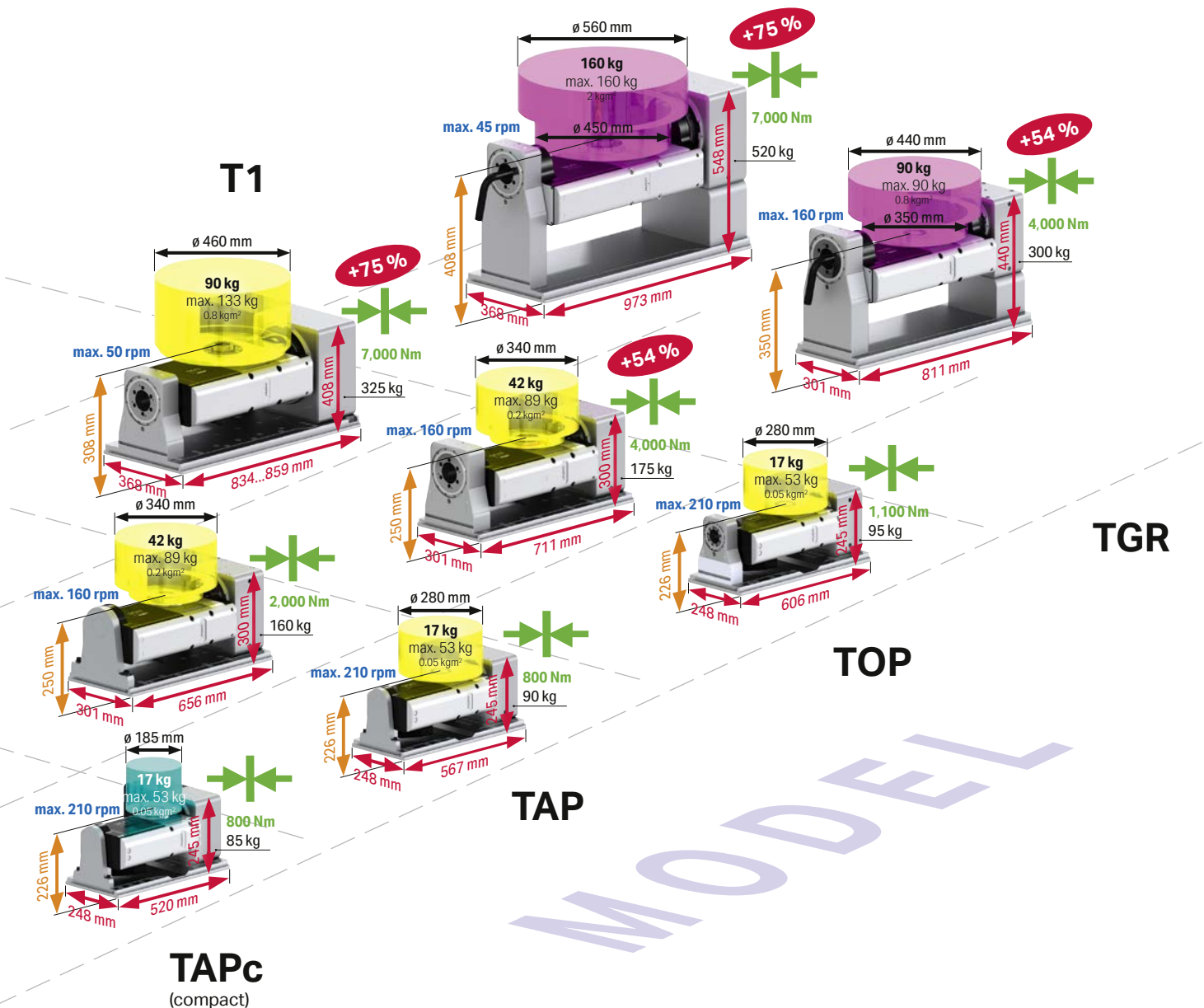

Weight data represent the standard load; higher weights possible, but require modification of rotational speed, acceleration and jerk limitation.

50x510	508510 (standard) or 508510 (high speed)
51x520	510520 (standard) or 511520 (high speed)
TIPc	Two-axis rotary table, no counter bearing, compact
TAPc	Two-axis rotary table, with supporting bearing, compact
TAP	Two-axis rotary table, with supporting bearing
TOP	Two-axis rotary table, with clamped counter bearing
TGR	Two-axis rotary table, with clamped counter bearing, specifically for grinding applications



More space for workpiece and fixtures

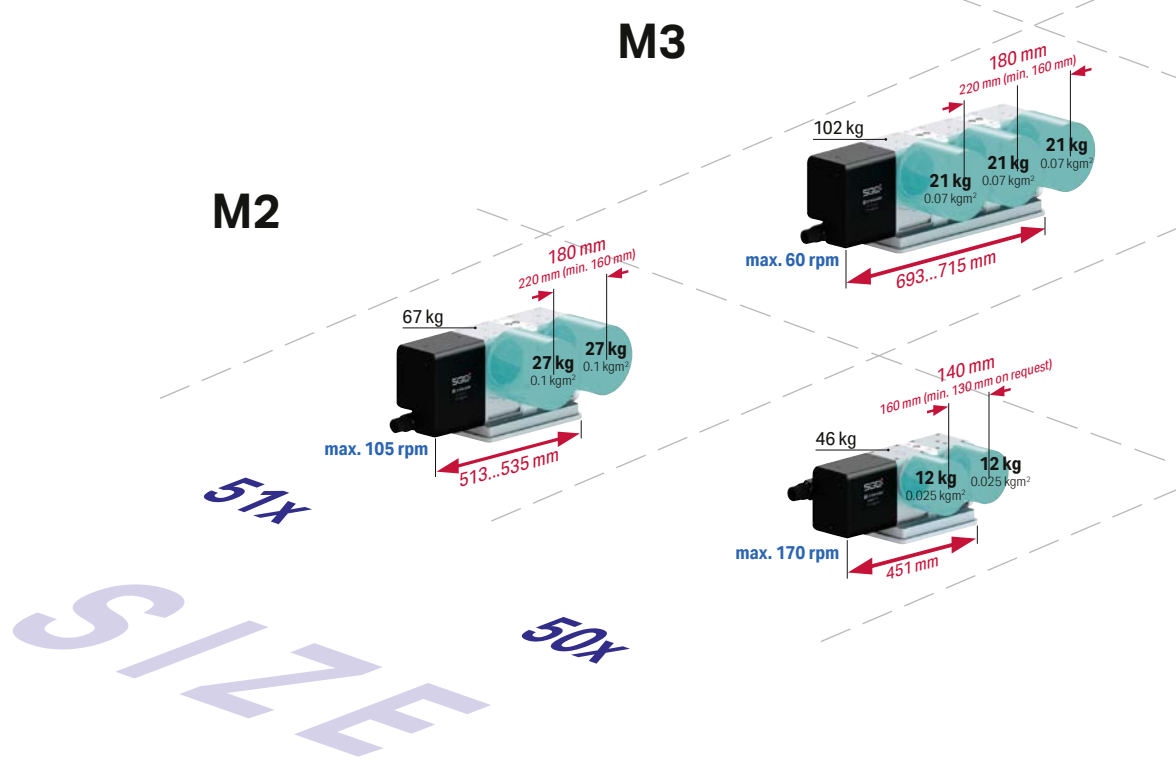



## News in brief

1. Up to **54 %** higher clamping torque in tilting axis
2. Fewer variant – more solution
3. Spindle distance min. **130 mm**
4. Spatially optimized arrangement of the dividing axis

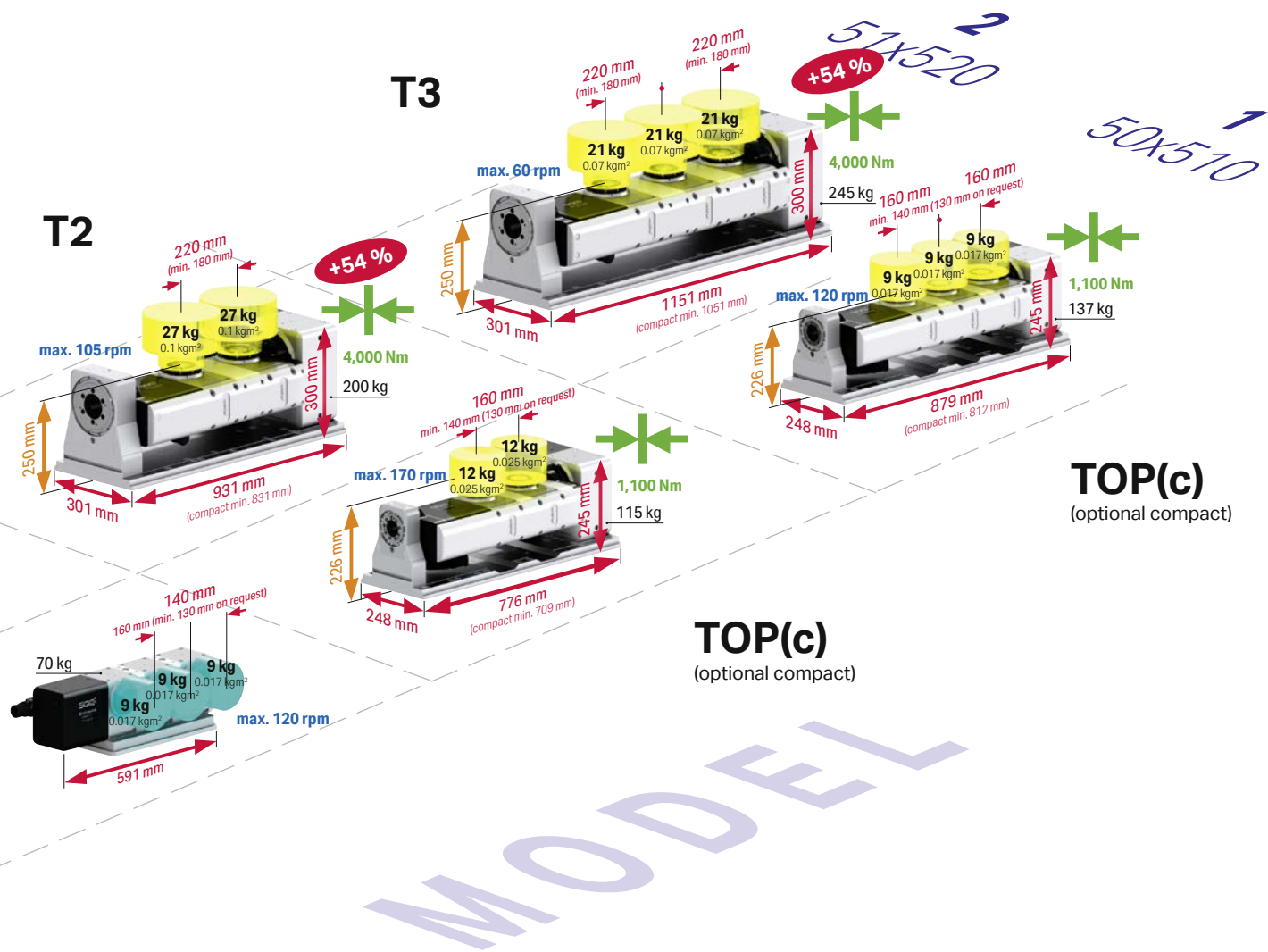

Weight data represent the standard load; higher weights possible, but require modification of rotational speed, acceleration and jerk limitation.

- 50x 507 (standard) or 508 (high speed)
- 51x 510 (standard) or 511 (high speed)
- M2 Single-axis, multi-spindle rotary table, 2-position
- M3 Single-axis, multi-spindle rotary table, 3-position
- T2 Two-axis multi-spindle rotary table, 2-position
- T3 Two-axis multi-spindle rotary table, 3-position

Extremely wide assortment for workpiece clamping.  
Standardized interface in front and rear: maximum universality

## Spindle accessories in rear

- + Rotary unions **up to 250 bar**
- + Clamping cylinder **23 kN at 120 bar**
- + Angular position measuring systems **as precise as  $\pm 1$  arcsec**



## Spindle accessories in front



## Tailstock and counter bearing



## ripas zero point clamping system



EA-507 with ripas auto and ripas adapter

## CAPTO clamping (on request)



EA-507 with CAPTO retrofit kit

Present in over 20 countries: from sales consultation to the final service



**Services from A to Z**

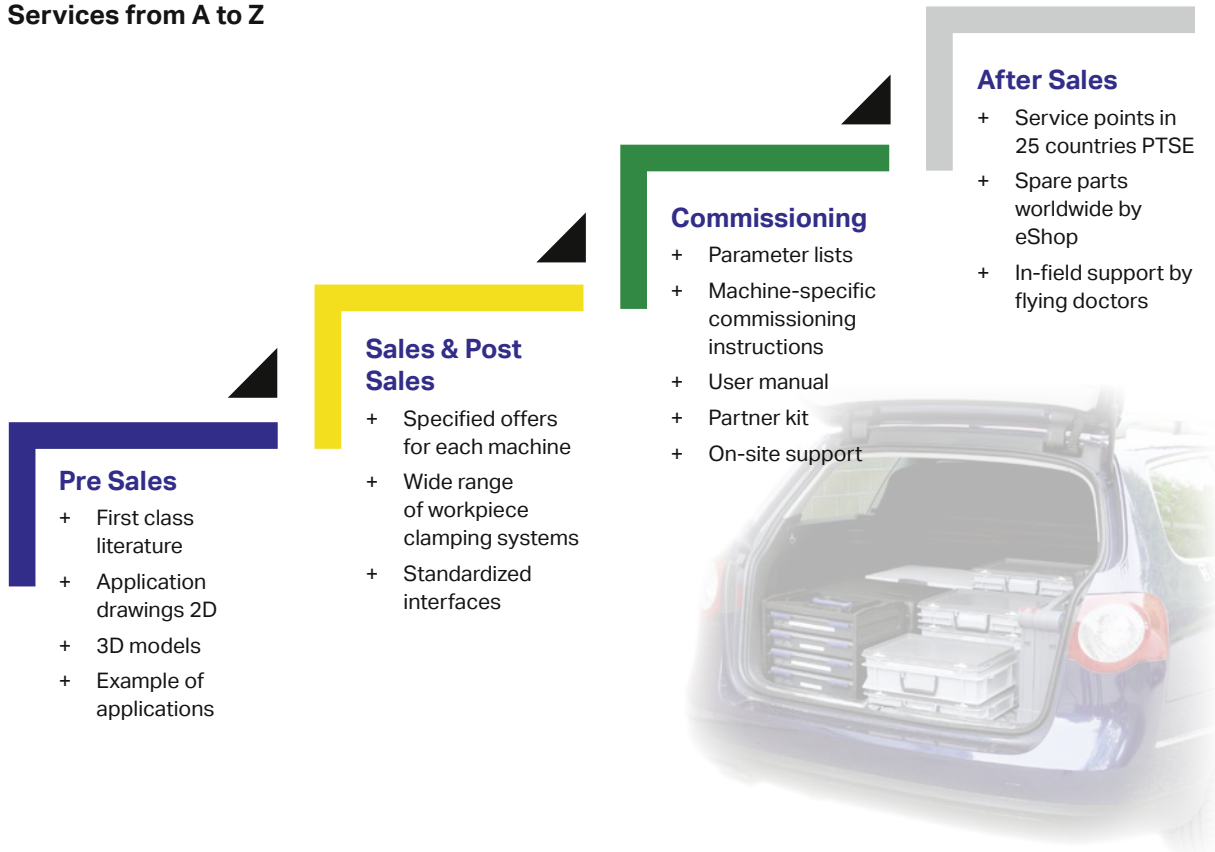

**Increase productivity – Extend lifecycle**

Comprehensive and professional services throughout the product life cycle – maximum availability with consistent quality and high productivity.

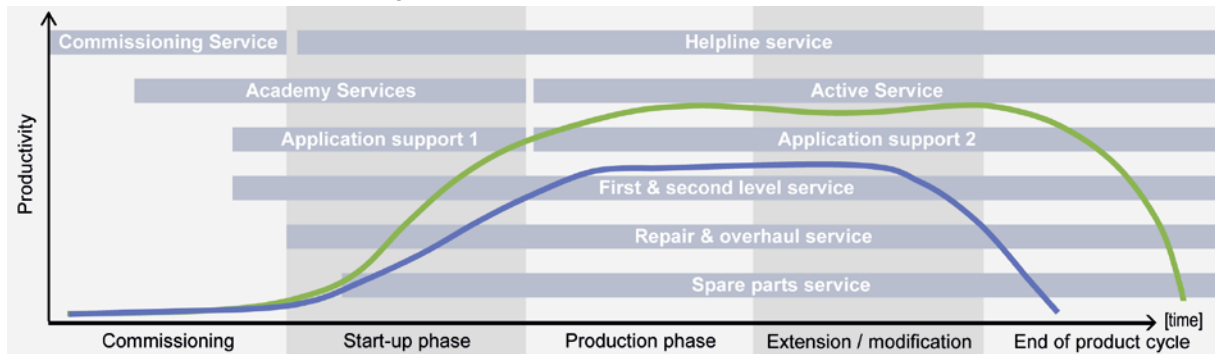

— Productivity with LifeCycle service products from pL LEHMANN  
 — Productivity without service support

For more information please see [www.lehmann-rotary-tables.com](http://www.lehmann-rotary-tables.com).



ROTARY TABLES · PRECISION TECHNOLOGY · SOFTWARE

#### Headquarters

PETER LEHMANN AG  
CH-3552 Bârau  
Phone +41 (0)34 409 66 66  
Fax +41 (0)34 409 66 00  
pls@plehmann.com  
www.lehmann-rotary-tables.com

#### Representatives / Agencies

##### Europe

- Austria
- Benelux
- Czech Republic (vacant)
- Finland
- France
- Germany
- Hungary (vacant)
- Italy
- Norway
- Poland
- Portugal
- Russia
- Slovenia
- Spain
- Sweden
- Turkey
- UK

##### America

- Brazil
- Canada
- Mexico
- USA

##### Asia

- China
- India
- Japan
- Malaysia
- Singapore
- South Korea
- Taiwan
- Thailand
- Vietnam

##### Africa

- South Africa

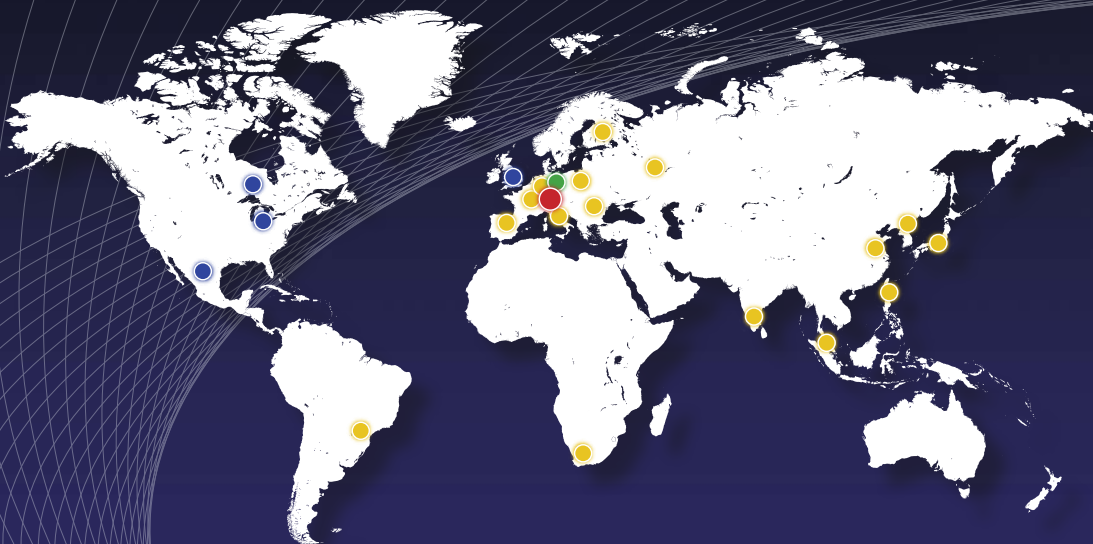

● Headquarters    ● direct sales partner    ● pL Solutions® partner    ● value added reseller & partner

More information (address, telephone number...) at [www.lehmann-rotary-tables.com](http://www.lehmann-rotary-tables.com)